

Operating Instructions

Replacement lamp unit Commercial Use

Model No. **ET-LAC300**
ET-LAC200

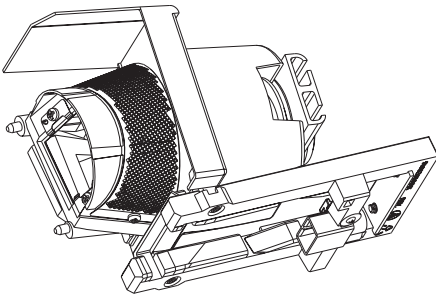

ET-LAC300

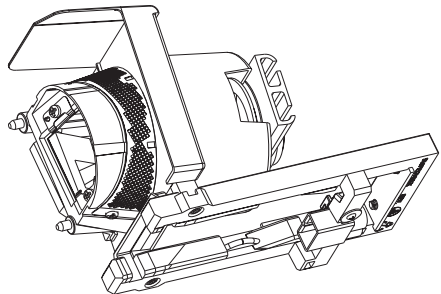

ET-LAC200

Thank you for purchasing this Panasonic product.

- Please read these operating instructions and the projector operating instructions carefully, and then use this product correctly.
- Before using this product, be sure to read [Read this first!] (Page 2).
- Please save this manual for future use.

WARNING:

Do not disassemble the lamp unit.

If the lamp breaks, it could cause injury.

Lamp replacement

The lamp has high internal pressure. If improperly handled, an explosion and severe injury or accidents will result.

- The lamp can easily explode if struck against hard objects or dropped.
- Before replacing the lamp, be sure to disconnect the power plug from the wall outlet. Electric shocks or explosions can result if this is not done.
- When replacing the lamp, turn the power off and allow it to cool for at least 1 hour before handling it otherwise it can cause burns.

CAUTION:

Do not use the old lamp unit.

If used it could cause lamp explosion.

If the lamp has broken, ventilate the room immediately. Do not touch or bring your face close to the broken pieces.

Failure to observe this will cause the user to absorb the gas which was released when the lamp broke and which contains nearly the same amount of mercury as fluorescent lamps, and the broken pieces will cause injury.

- If you believe that you have absorbed the gas or that the gas has got into your eyes or mouth, seek medical advice immediately.
- Ask your dealer about replacing the lamp unit and check the inside of the projector.

Notice (USA only)

Hg-LAMP CONTAINS MERCURY, Manage in Accord with Disposal Laws,

See: www.lamprecycle.org or 1-888-411-1996

Accessories

The following accessories (2 x filter/bagged) are included.

Air filter (rear) x 1

Air filter (side) x 1

Attention

- Dispose of the packaging materials properly after unpacking the product.

Replacing the Lamp unit & Air filters

Notes on replacing the lamp unit

- The light source lamp is a glass component. If it is hit on a hard object or dropped, breakage may occur. Be careful when handling a light source lamp.
- A Phillips screwdriver is necessary when replacing the lamp unit. Hold the screwdriver firmly.
- Grip the base when you remove the lamp unit. Some parts of the lamp unit are sharpened and may cause injury.
- The lamp contains mercury. Contact the local government office or distributor for the correct disposal of the old lamp unit.
- When replacing the lamp because it has stopped illuminating, there is a possibility that the lamp may be broken. If replacing the lamp of a projector which has been installed on the ceiling, you should always assume that the lamp is broken, and you should stand to the side of the lamp cover, not underneath it. Remove the lamp cover gently. Small pieces of glass may fall out when the lamp cover is opened. If pieces of glass get into your eyes or mouth, seek medical advice immediately.

Attention

- When the projector is mounted on a ceiling, do not work with your face close to the projector.
- Attach the lamp unit and the lamp cover securely.
- Be sure to use the lamp unit specified.
- Do not remove any screws other than those indicated when replacing the lamp unit. If this is not observed, electric shocks, burns or other injuries may occur.
- Do not loosen other than designated screws.
- Please replace the air filters together when replacing the lamp unit.
- After replacing the lamp unit, make sure to reset the usage time in the [Clear Lamp Hours] menu.

■ Replacement procedure

- 1) Turn off the Power and then unplug the AC power cord. Wait at least 1 hour and make sure the lamp unit and surroundings are cool.
- 2) Use a Phillips screwdriver to loosen the Lamp cover screws (2 screws) and open the lamp cover.
- 3) Use a Phillips screwdriver to loosen the Lamp unit screws (2 screws) until the screws turn freely. Hold the used lamp unit by its base, and pull it gently from the projector.

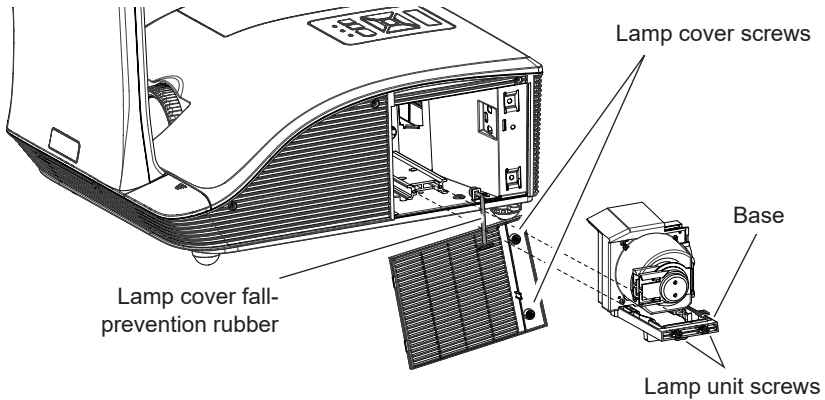

- 4) Insert the new lamp unit in correct direction. Tighten the Lamp unit screws (2 screws) securely with a Phillips screwdriver.
- 5) Close the lamp cover, and tighten the Lamp cover screws (2 screws) securely with a Phillips screwdriver.
 - When installing the lamp cover, make sure the lamp cover falling-prevention rubber not be clamped.
- 6) Clean up the dust on the projector and around the air vents.
- 7) Slowly pull out the air filters from rear and side.

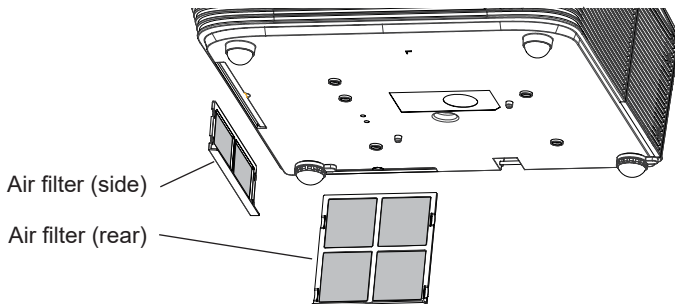

8) Install the new air filters (Replacement air filters).

- To install the air filters, reverse the previous steps until you hear a "click" sound.

9) Connect the power plug to the power outlet and then turn on the Power. Press <MENU> button to display main menu.

10) Press ▲ ▼ to select [Options] and then press ►.

11) Press ▲ ▼ to select [Lamp Settings] and then press ► to display the setting dialog box.

12) Press ▲ ▼ to select [Clear Lamp Hours] and then press ► to display adjusting box.

13) Press ▲ ▼ to select [Yes] and then press ►.

- The lamp usage time is reset.

14) Press <MENU> button to return to main menu.

15) Press ▲ ▼ to select [Dust Filter Reminder] and then press ► to display the setting dialog box.

16) Press ▲ ▼ to select [Cleaning up Reminder] and then press ► to display the adjusting dialog box.

17) Press ▲ ▼ to select [Yes] and then press ►.

- Reset the air filter hour counter after replacing the air filters.

Attention

- After replacing the Air filters, make sure to reset the usage time in the [Cleaning up Reminder] menu.
- The air filters must always be installed in the projector. Failure to do so will result in malfunctions due to foreign materials, such as dust, entering the projector.

Disposal of Old Equipment

Only for European Union and countries with recycling systems



This symbol on the products, packaging, and/or accompanying documents means that used electrical and electronic products must not be mixed with general household waste.

For proper treatment, recovery and recycling of old products, please take them to applicable collection points in accordance with your national legislation.

By disposing of them correctly, you will help to save valuable resources and prevent any potential negative effects on human health and the environment. For more information about collection and recycling, please contact your local authority.

Penalties may be applicable for incorrect disposal of this waste, in accordance with national legislation.

Product information (for Turkey only)

AEEE Yönetmeliğine Uygundur

Panasonic Connect Co., Ltd.

Web Site : <https://panasonic.net/cns/projector/>

© Panasonic Connect Co., Ltd. 2022

CH1212JG1062 -PT
Printed in China