

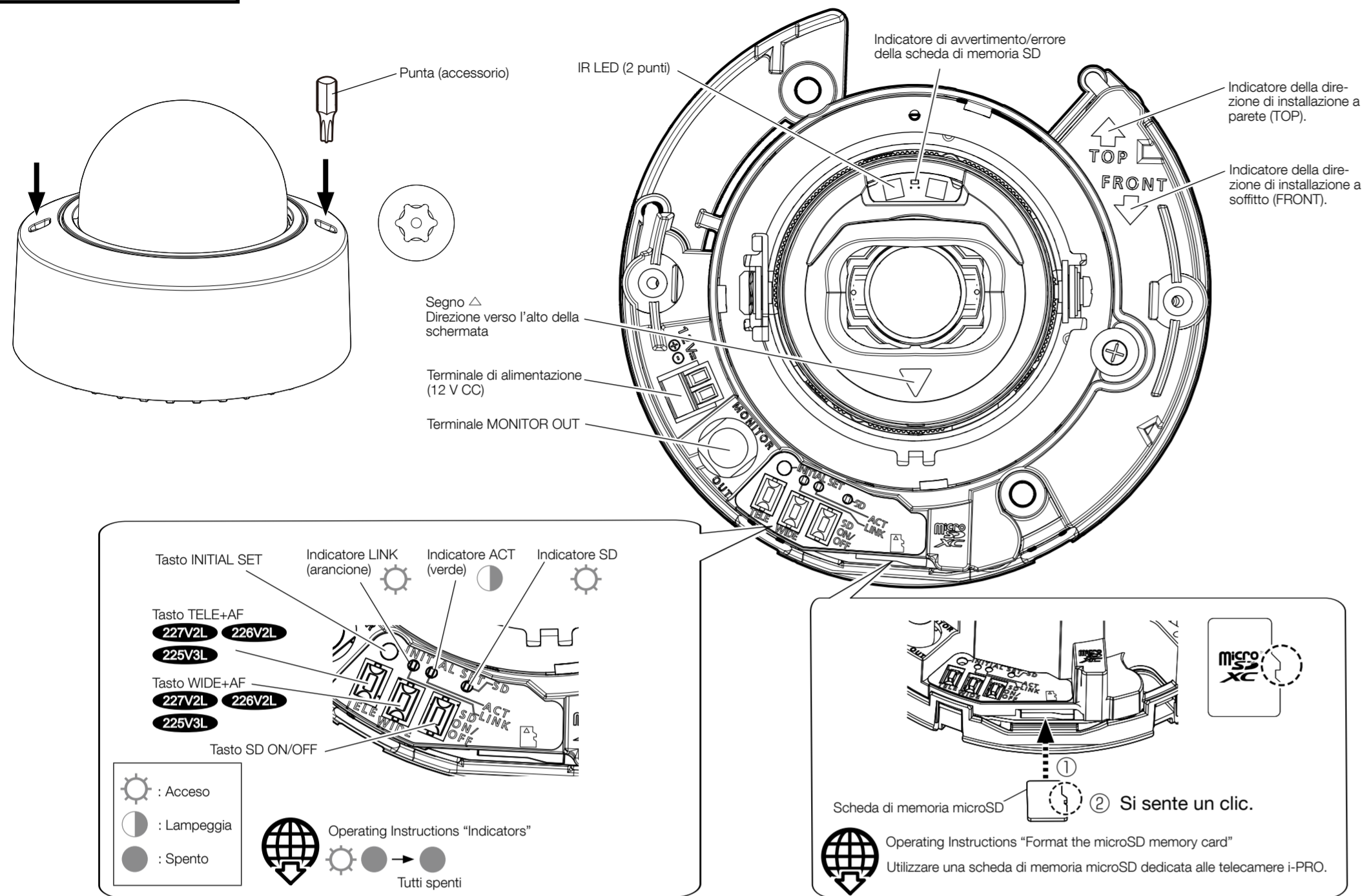



## Parti e funzioni



## Passaggio 3

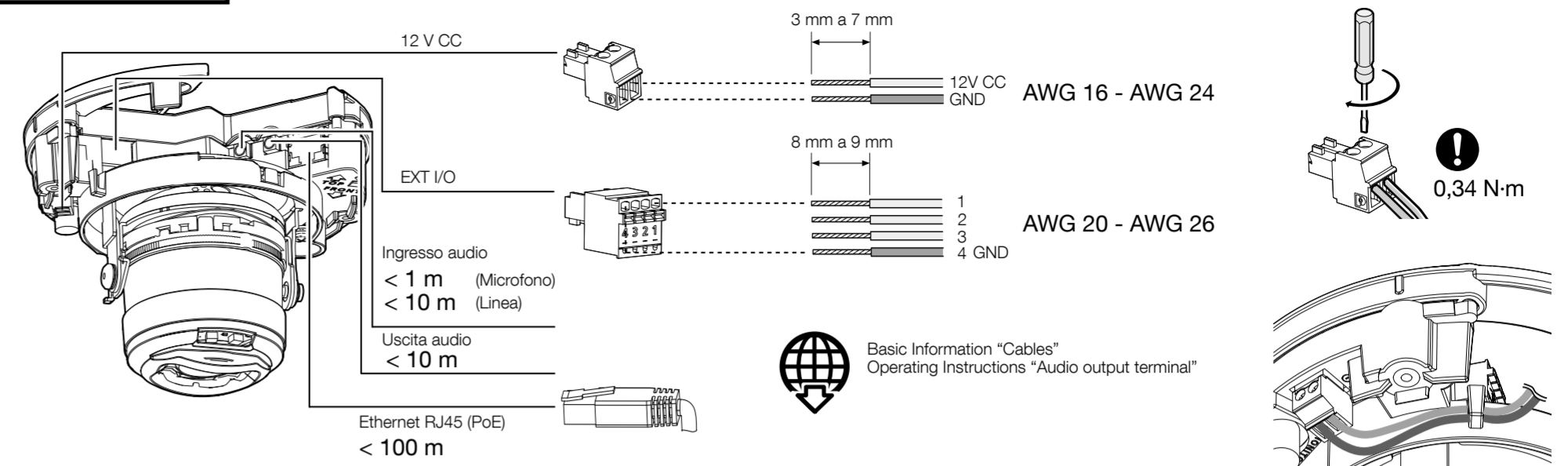

## Passaggio 4

**Passaggio 4:**

- Resistenza alla trazione minima: 196 N (per vite)
- Viti di fissaggio: M4 (da procurarsi localmente)

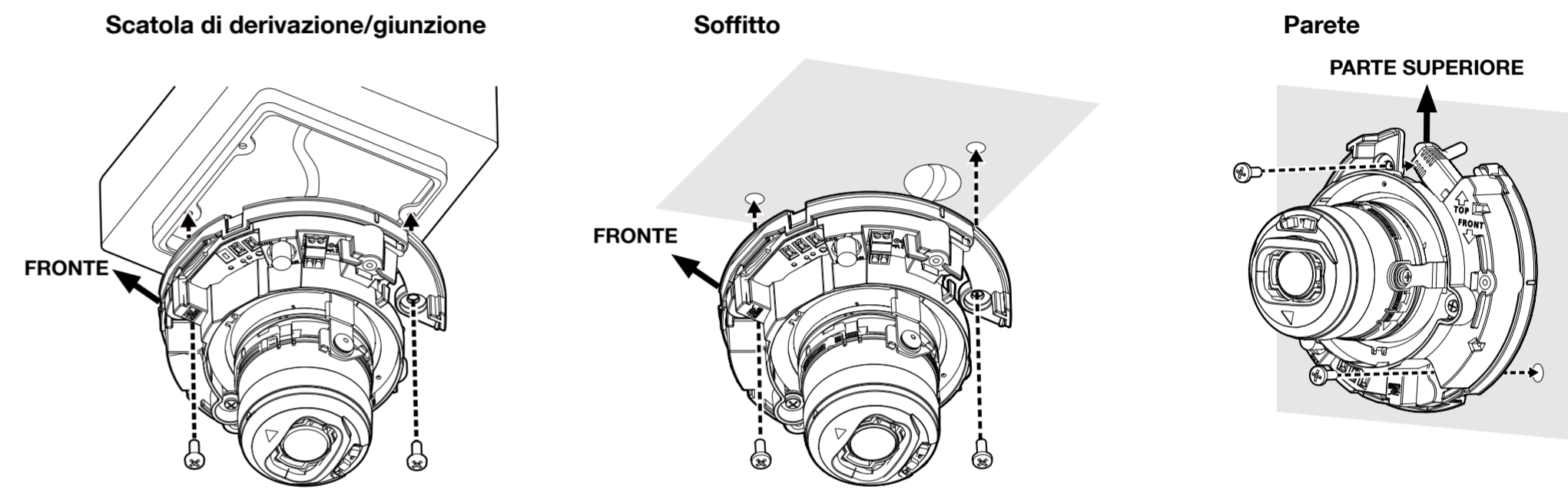

## Passaggio 1

### Preparativi

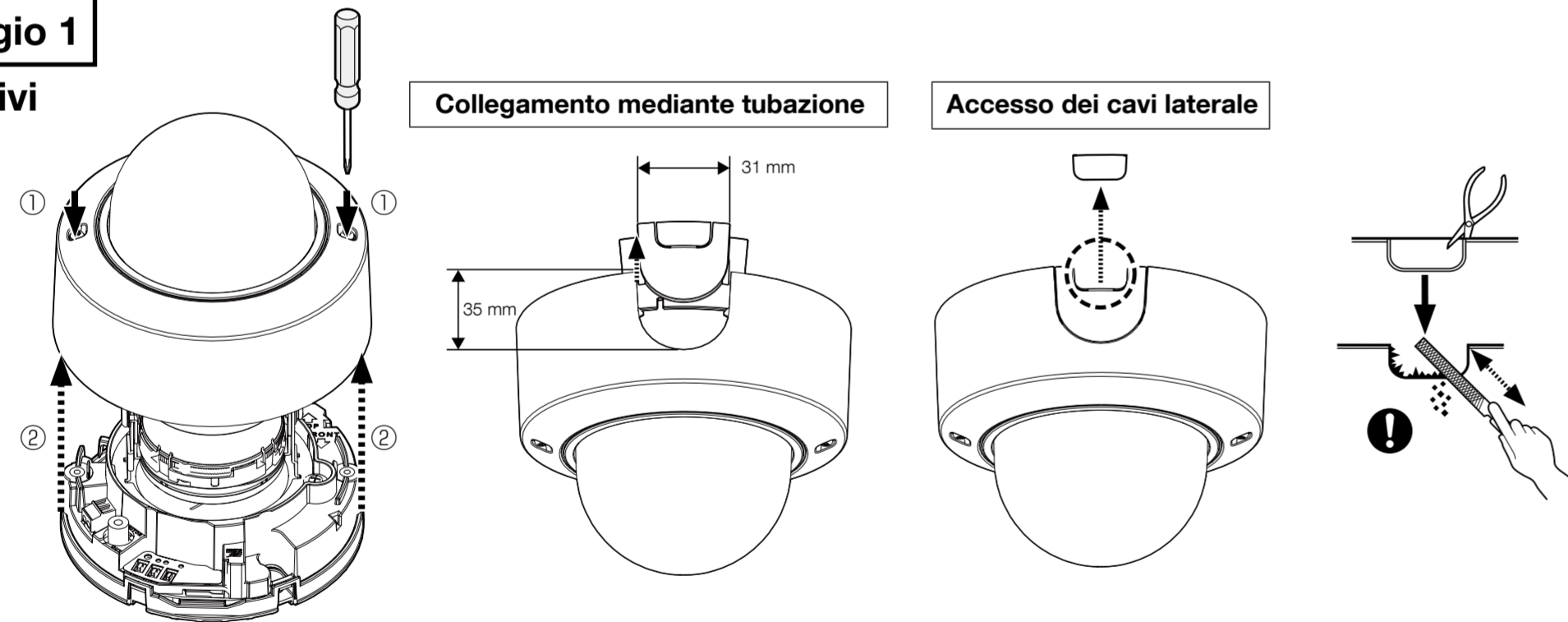

## Passaggio 2

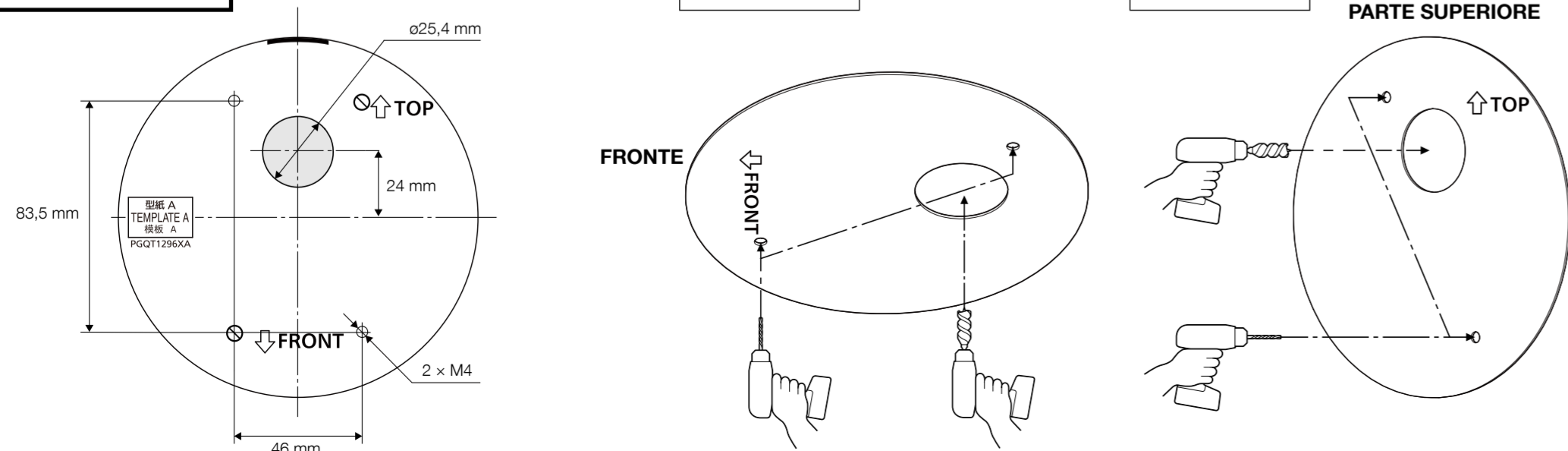

## Passaggio 5

**Passaggio 5:** → Accensione (CC 12 V/PoE)  
Se è presente una pellicola di protezione sull'obiettivo, rimuoverla.

