

## Installationshandbuch











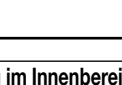
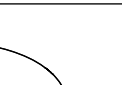















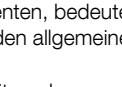
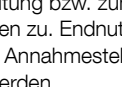
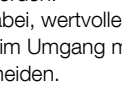
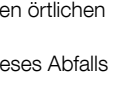

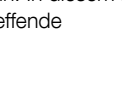
**Beiliegende Einbauanleitung**

### Netzwerkamera

**Nur für die professionelle Anwendung**

**Verwendung im Innenbereich**

**Modell-Nr.**
**WV-S22700-V2L**
**WV-S22600-V2L**
**WV-S22500-V3L**
**WV-S22500-F6L**
**WV-S22500-F3L**











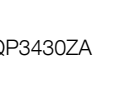

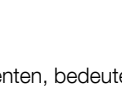
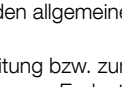
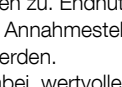
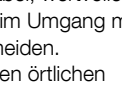
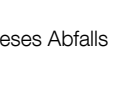
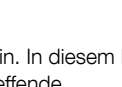
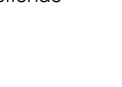
Die in diesen Dokumenten verwendete "«Kontroll-Nr.: C\*\*\*\*»" kann zur Suche auf unserer Website für technische Informationen (https://i-pro.com/global/en/surveillance/training-support/support/technical-information) verwendet werden und leitet Sie zu den richtigen Informationen weiter.

- Bitte lesen Sie diese Bedienungsanleitung vor dem Anschließen und der Inbetriebnahme dieses Produkts aufmerksam durch und halten Sie sie jederzeit griffbereit.
- Die microSDXC/ microSDHC/ microSD-Speicherkarte sind unter dem Begriff microSD-Speicherkarte zusammengefasst.
- Die Abbildungen in diesem Handbuch, die das äußere Aussehen und Teile des Geräts zeigen, können aufgrund laufender Verbesserungen geringfügig vom tatsächlichen Produkt abweichen.

Bitte lesen Sie diese Bedienungsanleitung vor dem Anschließen und der Inbetriebnahme dieses Produkts aufmerksam durch und halten Sie sie jederzeit griffbereit.

Die microSDXC/ microSDHC/ microSD-Speicherkarte sind unter dem Begriff microSD-Speicherkarte zusammengefasst.

Die Abbildungen in diesem Handbuch, die das äußere Aussehen und Teile des Geräts zeigen, können aufgrund laufender Verbesserungen geringfügig vom tatsächlichen Produkt abweichen.

	
	
	
	
	
	
	
	
	
	



# Teile und Funktionen

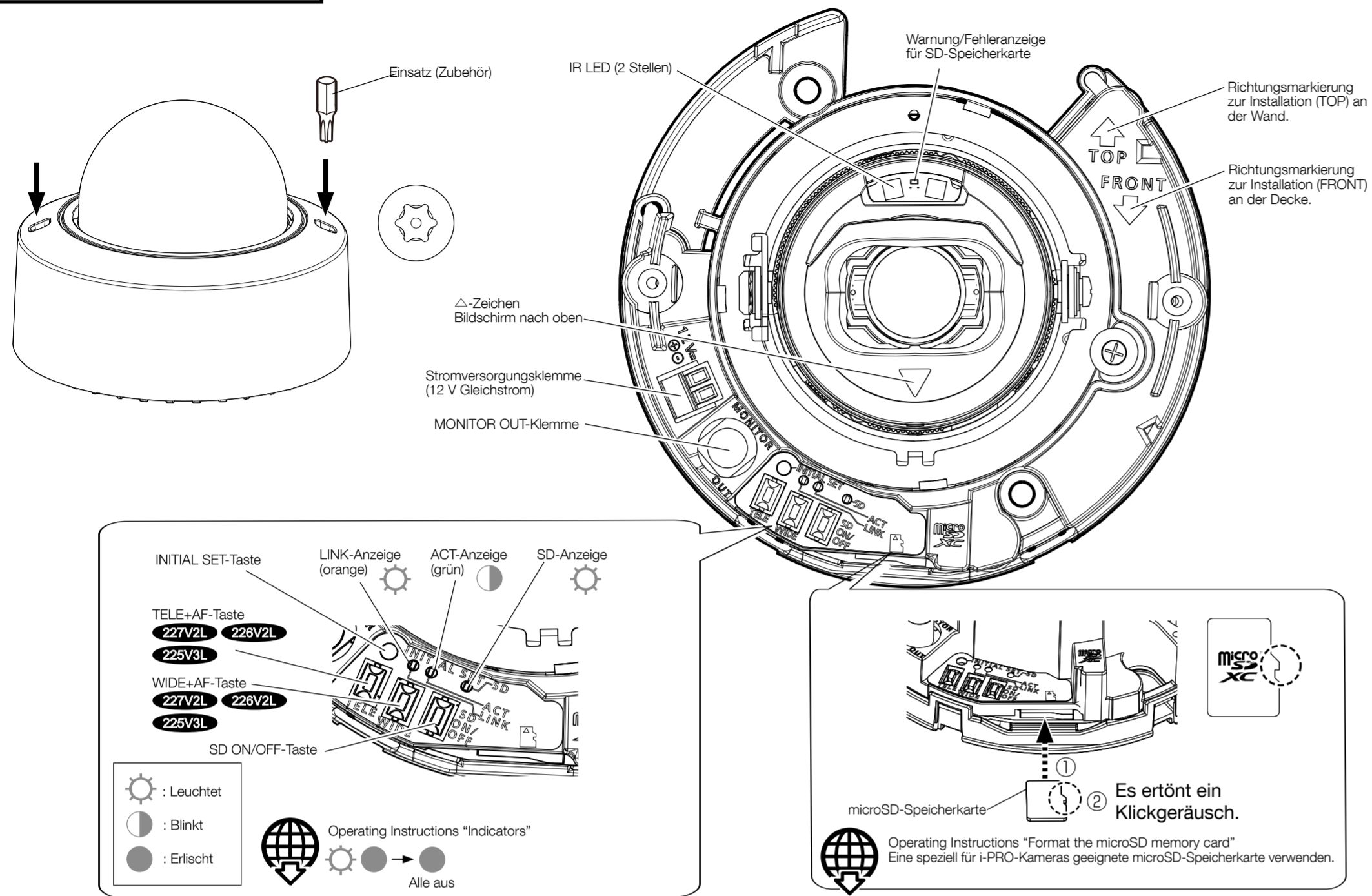

# Schritt 3

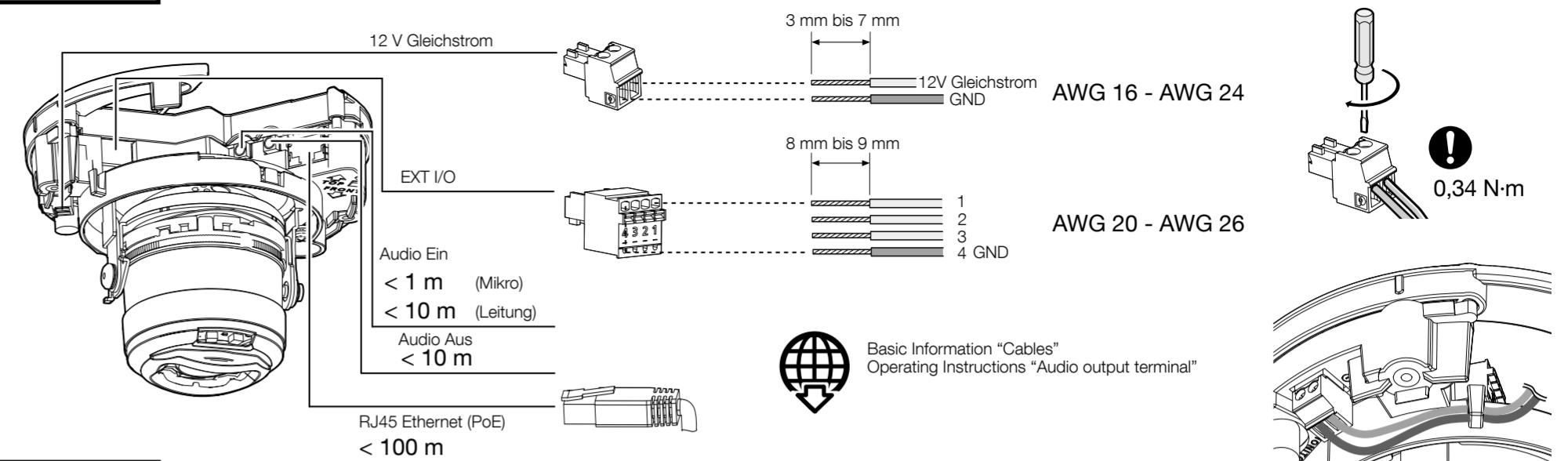

# Schritt 4

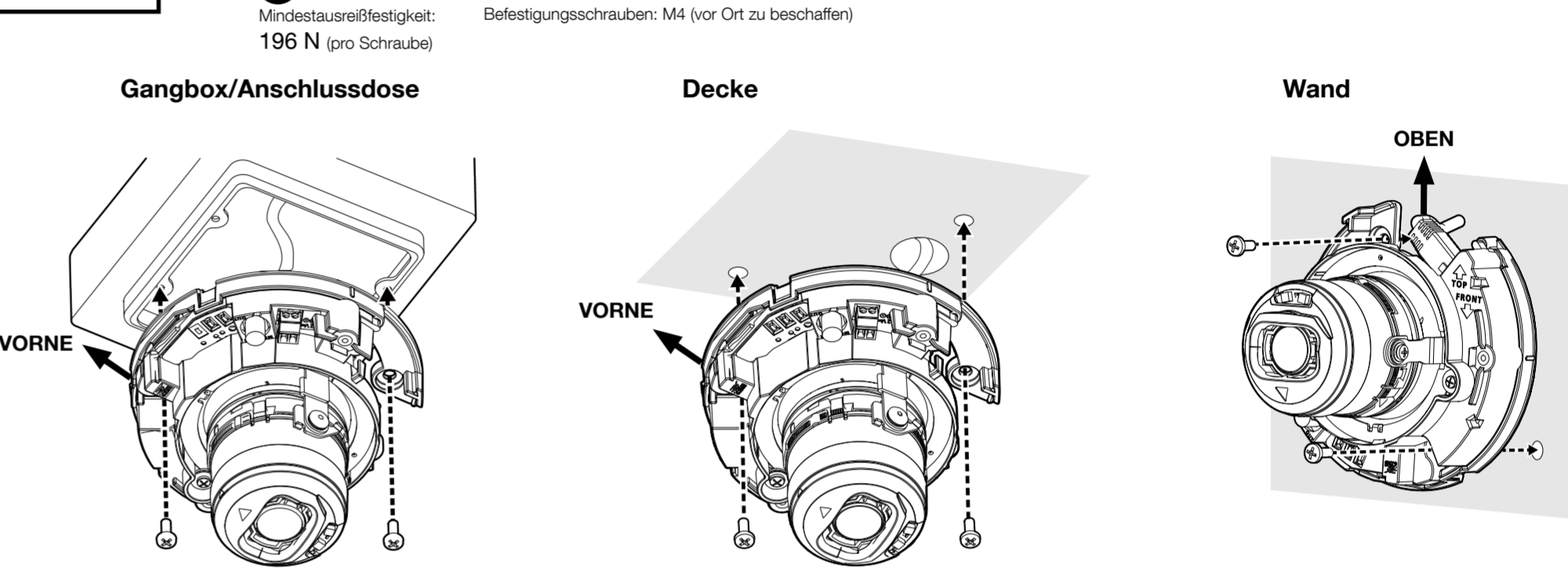

# Schritt 1

## Vorbereitungen

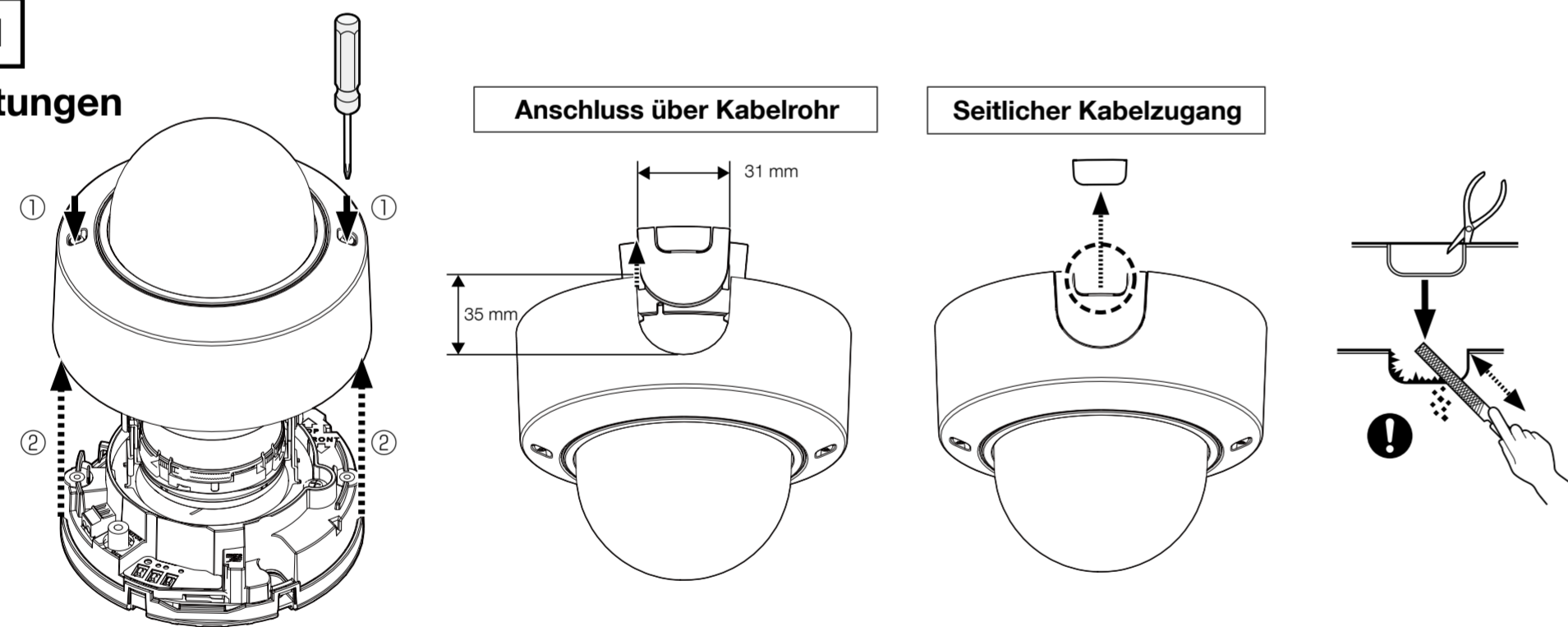

# Schritt 2

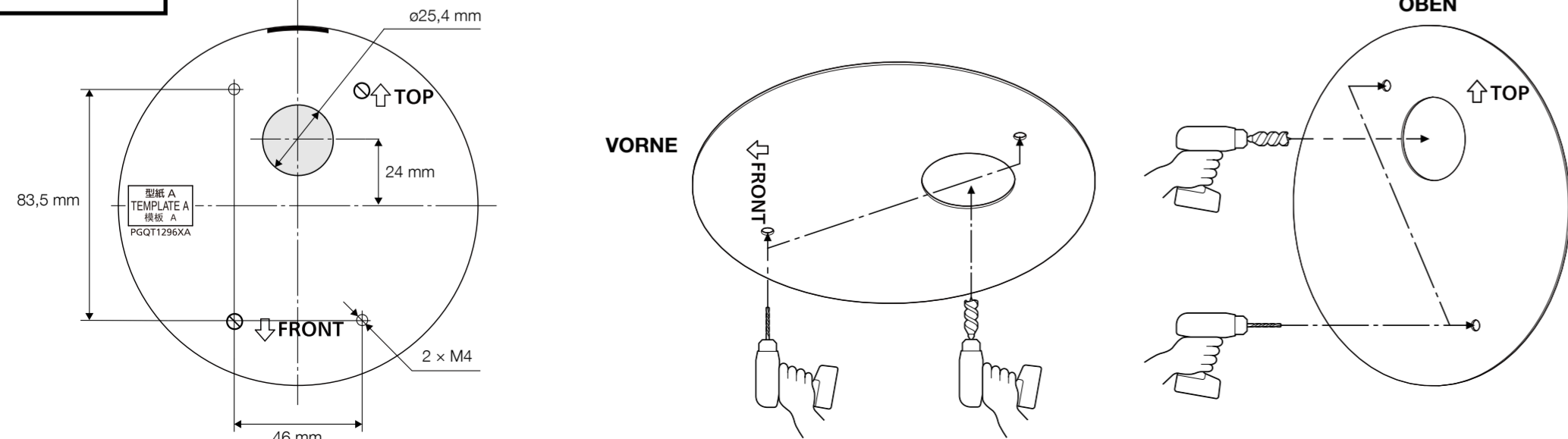

# Schritt 5

→ Strom Ein (12 V Gleichstrom/PoE)  
Wenn sich eine Schutzfolie auf dem Objektiv befindet, entfernen Sie diese.

