

Operating Instructions

Included Installation Instructions

RJ45 Ethernet Cable For professional use only.

Model No. **WV-QCA500A** (1 pc.)

WV-QCA500APK (10 pcs.)

- Before attempting to connect or install this product, please read these instructions carefully and save this manual for future use.
- The external appearance and other parts shown in this manual may differ from the actual product within the scope that will not interfere with normal use due to improvement of the product.
- Also read the Operating Instructions for the camera you are using.

Panasonic i-PRO Sensing Solutions Co., Ltd. assumes no responsibility for injuries or property damage resulting from failures arising out of improper installation or operation inconsistent with this documentation.

For U.S. and Canada:

Panasonic i-PRO Sensing Solutions Corporation of America

8550 Fallbrook Drive, Suite 200 Houston, Texas 77064
<https://i-pro.com/>

Panasonic Canada Inc.

5770 Ambler Drive, Mississauga, Ontario, L4W 2T3 Canada
1-877-495-0580
<https://www.panasonic.com/ca/>

For Europe and other countries:

Panasonic Corporation

<http://www.panasonic.com>

Panasonic i-PRO Sensing Solutions Co., Ltd.
Fukuoka, Japan

Authorised Representative in EU:

Panasonic Testing Centre
Panasonic Marketing Europe GmbH
Winsbergring 15, 22525 Hamburg, Germany



Preface

This product is an Ethernet extension cable with a waterproofing grommet. By using an RJ45 waterproof jack to convert the RJ45 network connector on an outdoor camera, it is possible to easily replace a past model that uses a waterproof connector.

For the latest information about the supported cameras, refer to our support website (https://security.panasonic.com/training_support/support/info/<Control No.:C0501>).

Specifications

Power source*1:	PoE (IEEE802.3af compliant)
Ambient operating temperature:	-40 °C to +60 °C {-40 °F to +140 °F}
Ambient operating humidity:	10 % to 100 % (no condensation)
Storage temperature:	-30 °C to +60 °C {-22 °F to +140 °F}
Storage humidity:	10 % to 95 % (no condensation)
Network*1:	10BASE-T / 100BASE-TX / RJ45 connector
Mass:	Approx. 35 g {0.08 lbs}

*1 The specifications of the network camera body apply.

Precaution

■ Do not attempt to disassemble or modify this product.

Failure to observe this may cause fire or electric shock. Consult the dealer for the repair or inspections.

■ Refer installation work to the dealer.

Installation work requires technique and experience. Failure to observe this may cause fire, electric shock, injury, or damage to the product. Be sure to consult the dealer.

■ Turn the power off when do wiring of this product.

Failure to observe this may cause electric shock. In addition, short circuit or wrong wiring may cause fire.

■ Correctly perform all wiring.

Short circuits in the wiring or incorrect wiring may cause fire or electrical shock.



Caution:

- This product is a professional equipment.
- Before attempting to connect or operate this product, please read these instructions carefully.

Standard accessories

Operating Instructions (this document) ... 1 pc. RJ45 waterproof connector cover..... 1 pc.
RJ45 waterproof connector cap..... 1 pc.

Precautions for installation

- Make sure to remove this product if it will no longer be used.

Installation

This product is used when attaching outdoor type network cameras using waterproof connectors. The outdoor dome type camera is used as an example when describing attachment procedures in these instructions.

Step 1

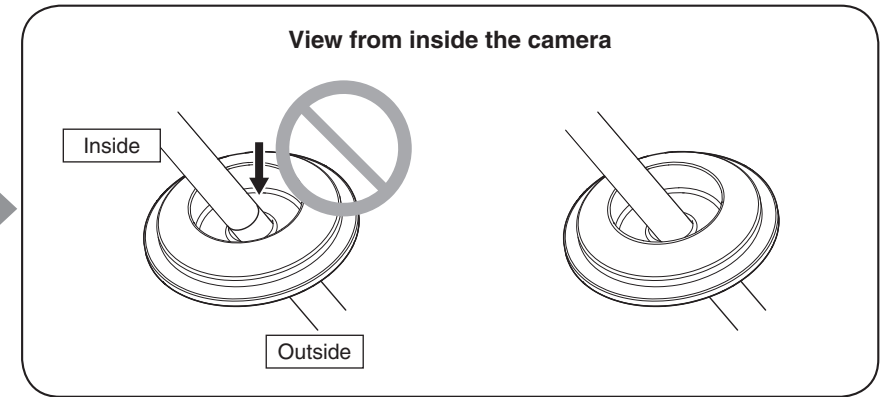
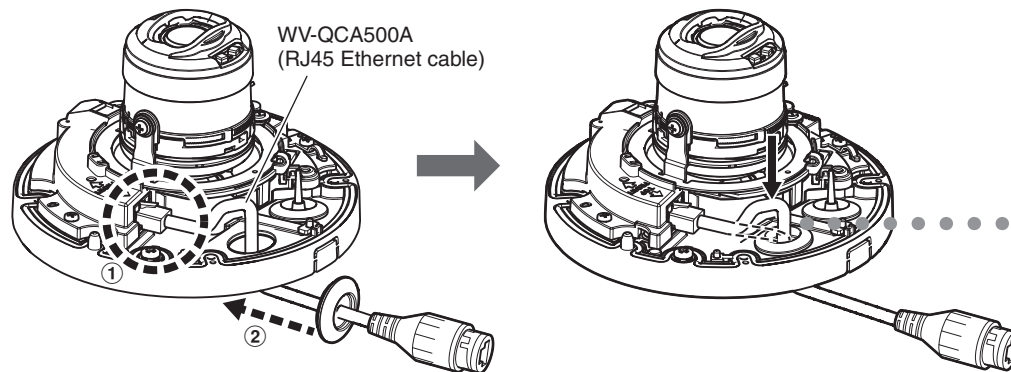

Step 2

- If the waterproof connector part of an existing camera is broken, rework the network cable and attach the included waterproof connector.
(→ Refer to the Installation Guide for the existing camera.)

