

Parts and functions The following are descriptions when using WV-U2540L and WV-U2530L.

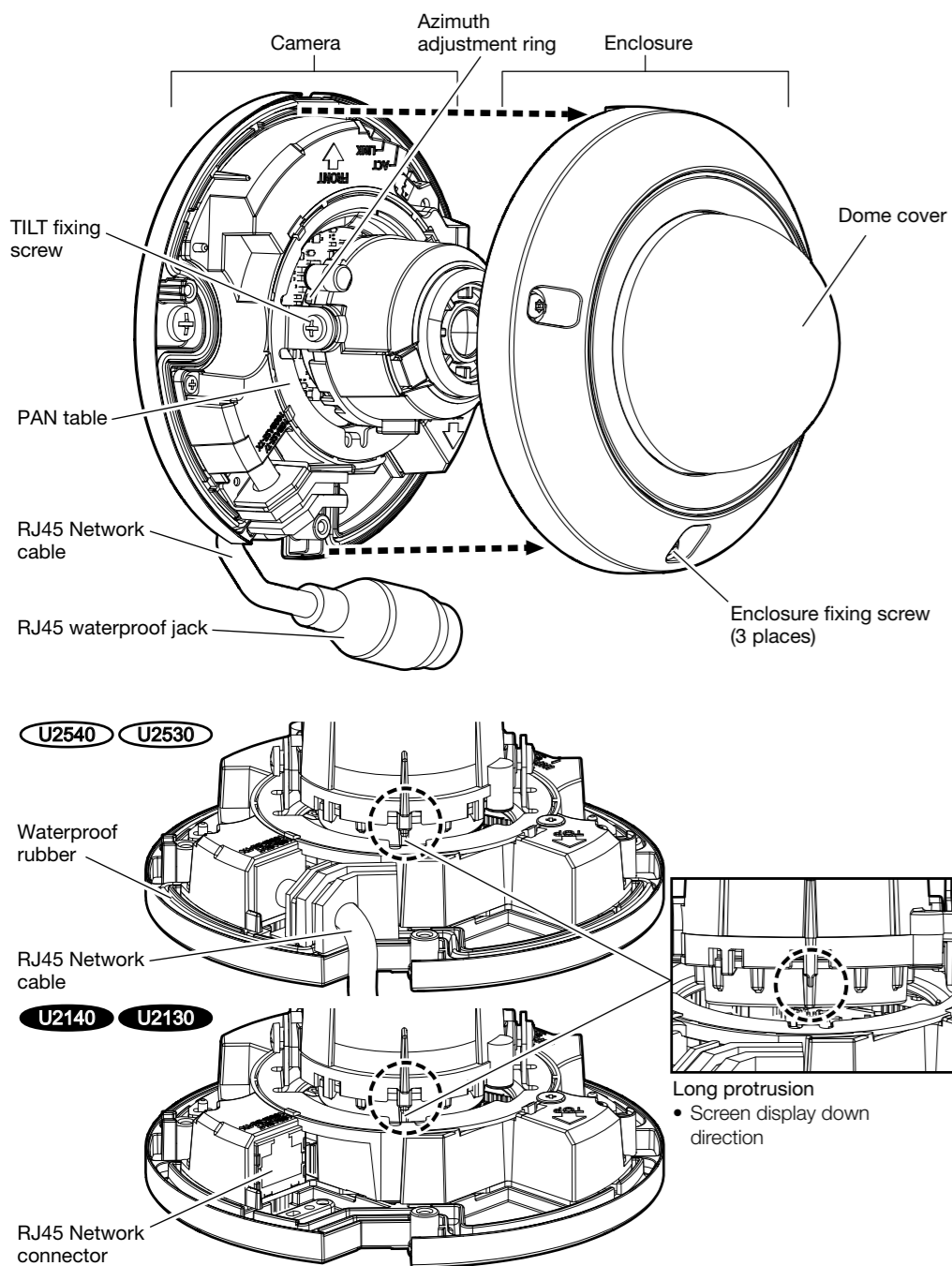

Indicators

Note:

- Lighting/blinking LED can be turned off with the software settings at any time. (The initial state is lighting or blinking.) Refer to the Operating Instructions, and set the LED to be solid off if necessary.

LINK indicator

When the camera is able to communicate with the connected device Lights orange

ACT indicator

When data is being sent via the network camera Blinks green (accessing)

Buttons

INITIAL SET button (Initializing)

Follow the steps below to initialize the network camera. Retry if the camera does not start up normally.

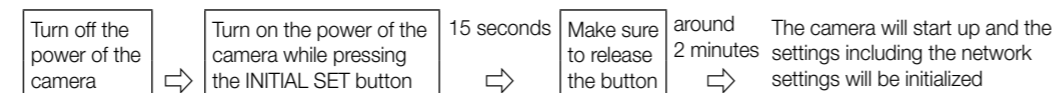

* Do not turn off the power of the camera during the process of initialization. Otherwise, it may fail to initialize and may cause malfunction.

Direction marker for installation (FRONT)

- FRONT should face the camera front (the side of the Panasonic logo).

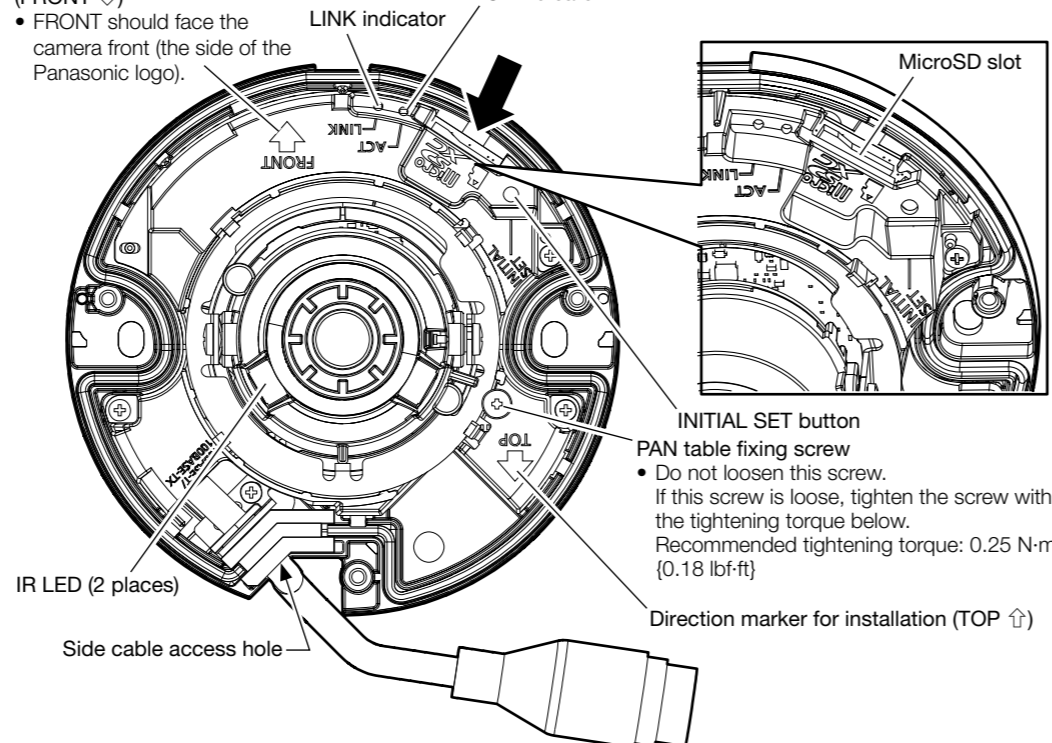

Step3 Making connections

IMPORTANT:

- Devices to which power can be supplied to this product are PoE hub and PoE power supplying equipment.
- Turn off each system's power supply before making a connection.

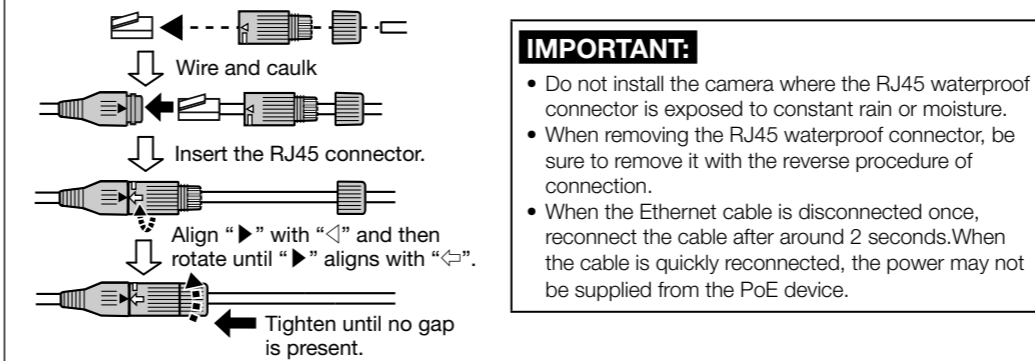
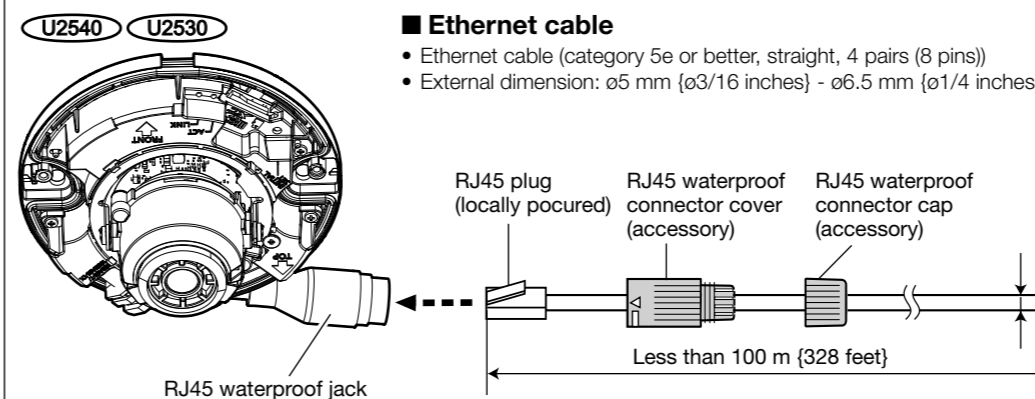

IMPORTANT:

- Do not install the camera where the RJ45 waterproof connector is exposed to constant rain or moisture.
- When removing the RJ45 waterproof connector, be sure to remove it with the reverse procedure of connection.
- When the Ethernet cable is disconnected once, reconnect the cable after around 2 seconds. When the cable is quickly reconnected, the power may not be supplied from the PoE device.

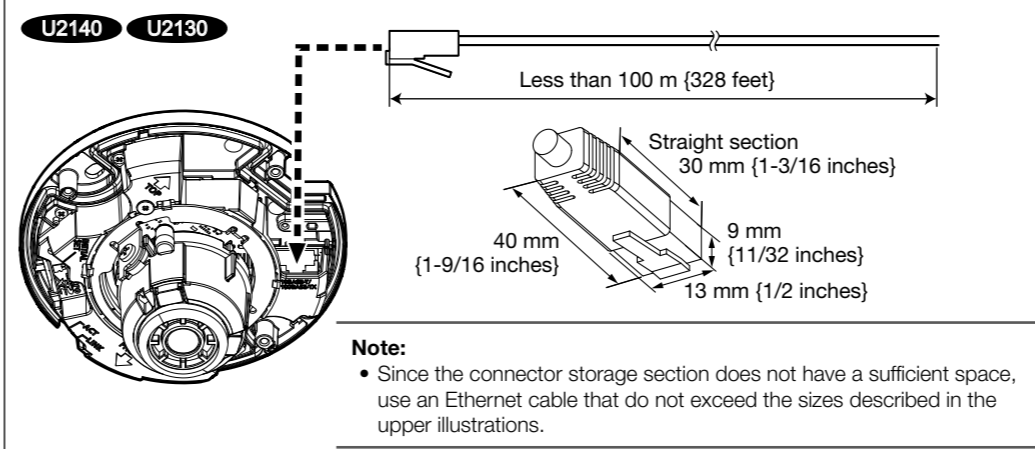

Note:
Since the connector storage section does not have a sufficient space, use an Ethernet cable that do not exceed the sizes described in the upper illustrations.

Step4 Mount the camera

Mount the camera on a wall or a ceiling

Secure the camera with fixing screws (2 pcs.) (M4: locally procured). Minimum pull-out strength: 196 N (44 lbf)

Mount the camera to a junction box

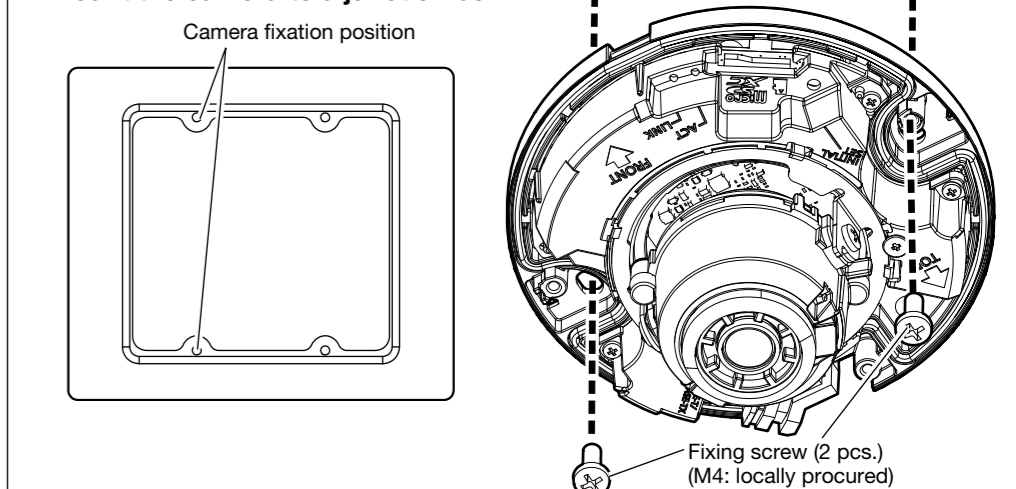

Step1 Preparations

[1] Loosen enclosure fixing screws (3 places), and remove the enclosure from the camera.

Loosen the screws using the bit (accessory).
Loosen the screws using a Phillips screwdriver.
The right illustrations are examples of WV-U2540L and WV-U2530L.

[2] Remove the cable for easy kitting

Do not use for actual installation.

[3] Remove the packaging from the inside of the dome cover.

[4] If necessary, insert a microSD memory card by referring to "Insert/remove a microSD memory card".

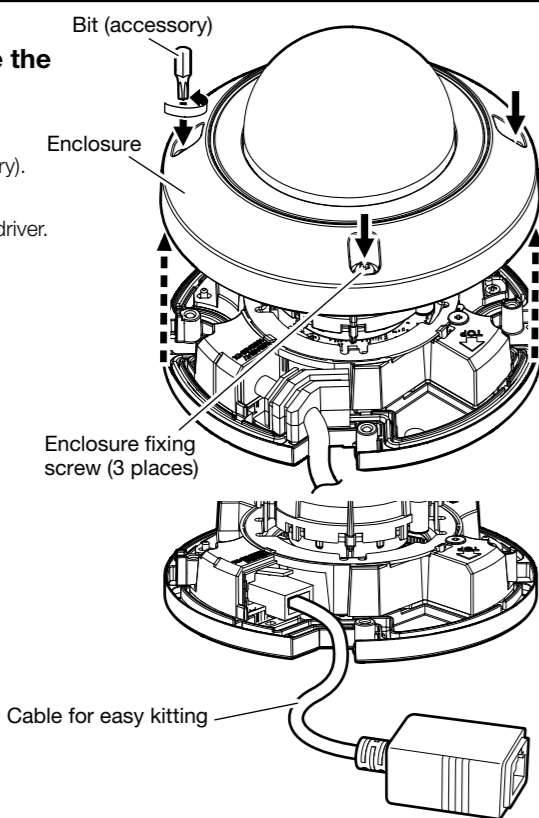

Step2 Processing the installation surface

Drill a hole in the installation surface. (2 screw holes / 1 cable access hole).

Note:

- When installing on a wall, make a hole so as to face the "↑TOP" mark of the template to the upper side.
- When installing on a ceiling, make a hole so as to face the "↓FRONT" mark of the template to the front side of the camera (in the direction of Panasonic logo).
- When running the cable using the side cable access hole of the camera, it is unnecessary to make a cable access hole on the installation surface.

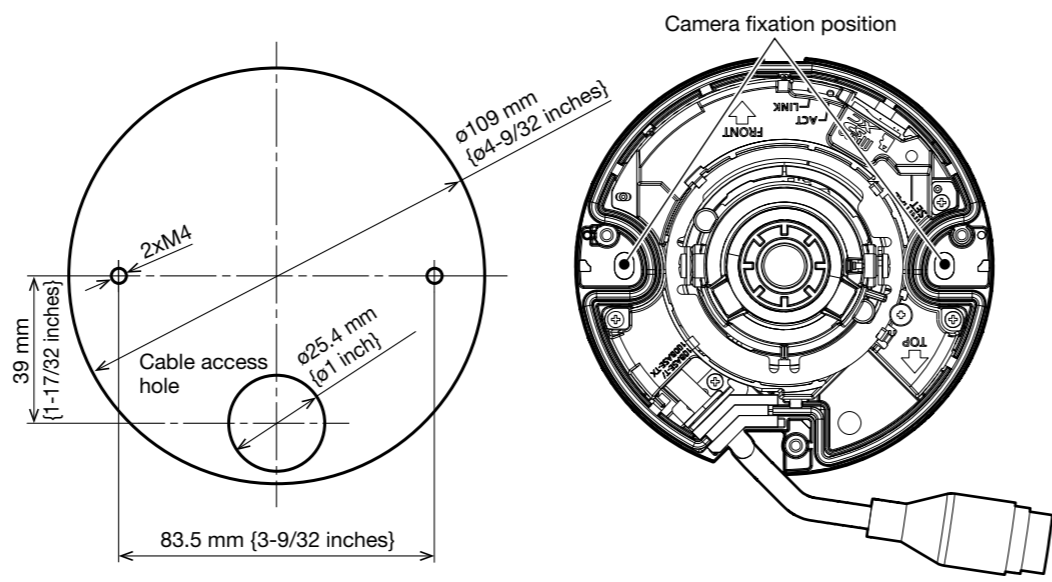

Step5 Adjustment

[1] Turn on the camera and remove the protection film from the lens.

[2] Download and launch the IP Setting Software and connect to the network by following information described on our support website <Control No.: 0123>.

[3] Adjust the camera direction.

Adjust the horizontal (PAN) angle, vertical (TILT) angle, and azimuth (YAW) angle while watching the screen of the PC on the network.
Horizontal (PAN) angle : ±175°
Vertical (TILT) angle : -30° to +80°
Azimuth (YAW) angle : ±100°
a) Hold the TILT fixing screw on the both sides of the camera with fingers and adjust the horizontal (PAN) angle. Rotate until the "Long protrusion" on the azimuth adjustment ring at the bottom of the camera part is turned at the opposite side of the image capturing direction.
b) Incline the TILT angle largely once and then adjust the azimuth (YAW) angle. After adjusting the azimuth (YAW) angle, adjust the vertical (TILT) angle again.

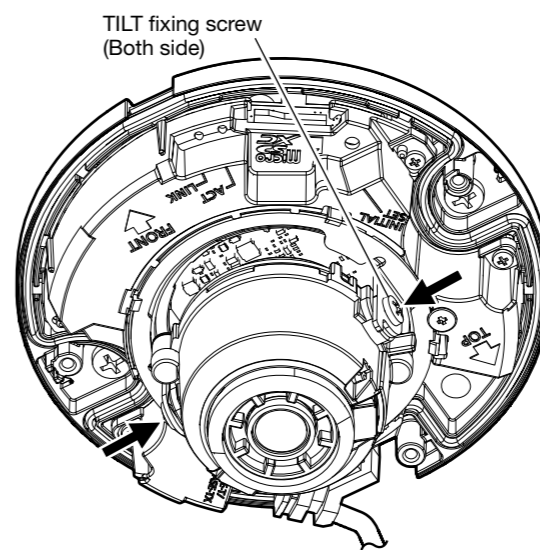

Note:

- When the camera is installed on a wall, the gradient viewed from the camera is backwards. Images displayed from the camera can be reversed by setting "Image rotation" to "180° (Upside-down)" in the setup menu. For information about configuring "Image rotation" in the setup menu, refer to the Operating Instructions.
- When the vertical angle is adjusted closer to level, a part of image may be seen double or a part of the camera may be seen on the screen or reflection of infrared ray may be seen on the screen during image capturing at night. In these cases, make the vertical angle smaller or adjust the zoom ratio.
- When adjusting the camera, do not touch IR LED sheets with your fingers.

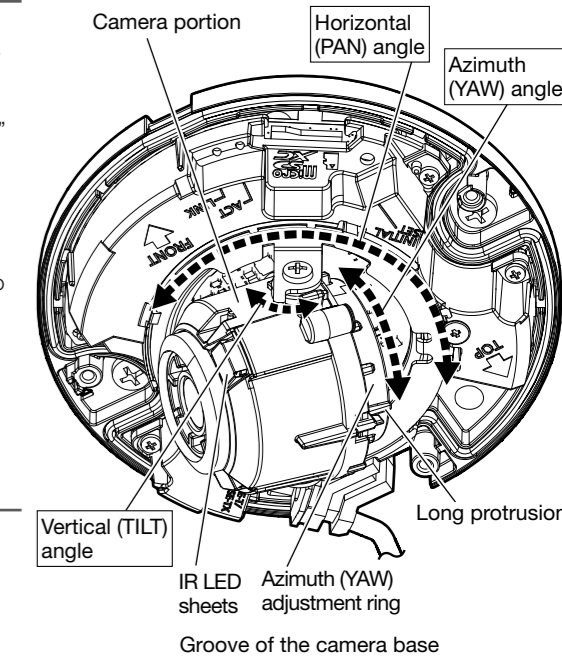

[4] Attach the enclosure and secure it by tightening the enclosure fixing screws (3 places).

Adjust the direction of the enclosure so as to match the claw of the enclosure with the groove of the camera base.

Tighten the screws using the bit (accessory). Recommended tightening torque: 0.70 N·m (0.52 lbf·ft)
Tighten the screws using a Phillips head screwdriver. Recommended tightening torque: 0.70 N·m (0.52 lbf·ft)

[5] After complete installation, remove the protection film from the dome cover.

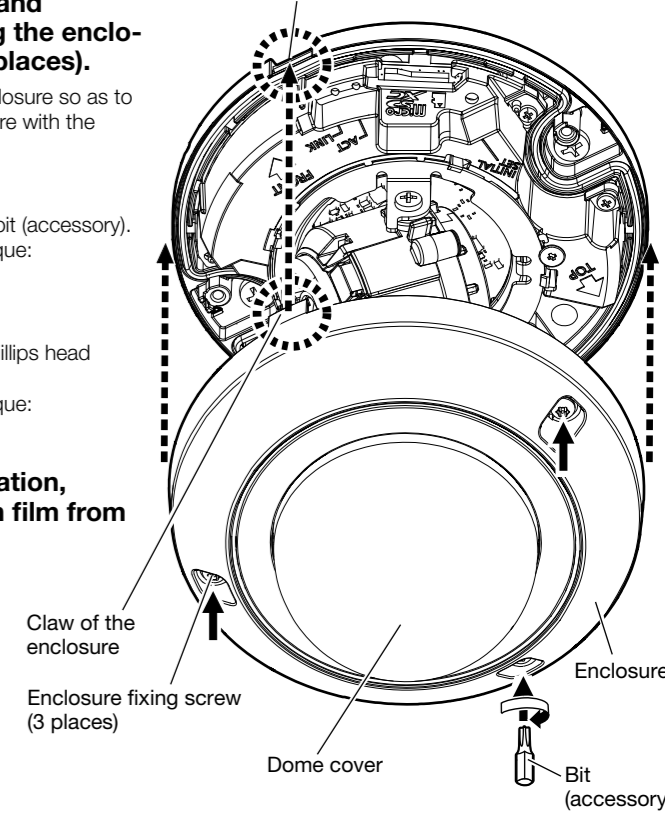

Insert / remove a microSD memory card

Insert a microSD memory card

- Remove the enclosure from the camera.
- Insert the microSD memory card into the end of the microSD slot and confirm that a clicking sound is made.

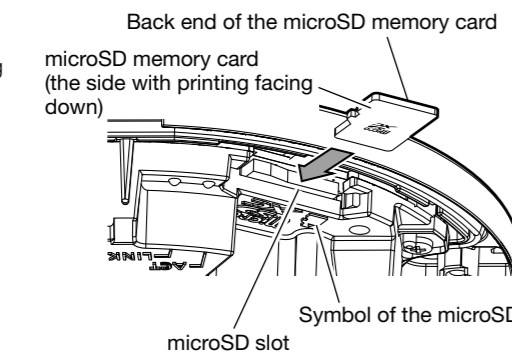

Note:

- Back end of the microSD memory card does not protrude over the surface line of the microSD slot.

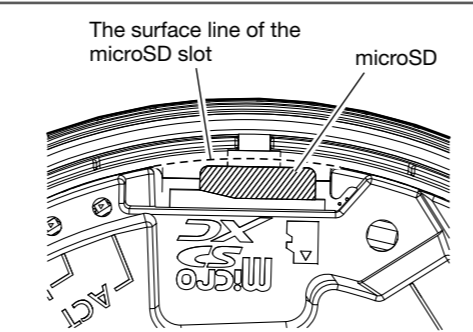

- Attach the enclosure to the camera again.

Remove a microSD memory card

When removing a microSD memory card, reverse the procedure.

- Remove the enclosure from the camera.
- Push the microSD memory card until a click sound is heard and then remove it from the socket.
- When removing, hold it by pinching the both ends of the rear end of the card with fingers. At this point, be careful not to let the memory card pop out and drop.
- Attach the enclosure to the camera again.

IMPORTANT:

- When removing a microSD memory card, make sure to set "SD memory card" to "Not use" on the [SD memory card] tab of the setup menu before removing the microSD memory card. After removing the memory card, set back the "SD memory card" to "Use". For information about the setup menu, refer to the Operating Instructions.

Note:

- When using a microSD memory card, format it using this product. Refer to the Operating Instructions for how to format a microSD memory card.
- Use the compatible microSD memory cards. Refer to our support website <Control No.: C0107> for latest information about the compatible microSD memory cards.