

“i-PRO SmartHD solutions”

Smart investment with more than just video surveillance.....

Better identification with more evidence

Smart investments lower your TCO

More than just video surveillance

Distinctive and versatile industry product solutions

i-PRO
SmartHD Solutions

Trademarks and registered trademarks

- HDMI, the HDMI logo and High-Definition Multimedia Interface are trademarks or registered trademarks of HDMI Licensing, LLC.
- “Super Dynamic”, “i-PRO” and “i-PRO SmartHD” logos are trademarks or registered trademarks of Panasonic Corporation.
- Android is a trademark of Google Inc.
- All other trademarks identified herein are the property of their respective owners.
- ONVIF and the ONVIF logo are trademarks of ONVIF Inc.

Important

- Safety Precaution: Carefully read the Important Information, Installation Guide and Operating Instructions before using this product.
- Panasonic cannot be responsible for the performance of the network and/or other manufacturers' products used on the network.
- The same catalog is provided for all countries. Some accessories may not be available in some countries.

Security Cautions

- When using the products in this catalog, take appropriate measures to avoid the following security breaches:
 - Disclosure of private information via the products.
 - Unauthorized use of products by a third party.
 - Interference or suspension of use of products by third party.

- All pictures are simulated.
- Design and specifications are subject to change without notice.
- These products may be subject to export control regulations.

DISTRIBUTED BY:

Panasonic

<http://security.panasonic.com>

[f http://www.facebook.com/PanasonicNetworkCamera](http://www.facebook.com/PanasonicNetworkCamera)

Printed in Japan (5A-003A)



i-PRO SmartHD Solutions for **Retail**

i-PRO
SmartHD Solutions

What are the current problems?



Loss prevention

- Shoplifting
- Unauthorized operation of self-checkout
- Burglary
- Pranks and tampering of products
- Damage to or destruction of store equipment
- Customer complaints such as trouble with change
- Work attitude of employees (ignoring work rules, slacking off)
- Parking lot trouble (car contact, theft, intrusion by suspicious individuals)
- Graffiti during night hours and on outer walls, etc.



Store management

- Multiple stores are not centrally managed
- Variation in employee quality and service across stores
- Time and costs incurred in patrolling multiple stores
- Sales opportunities lost due to lack of understanding regarding customer segments and trends



Existing analog equipment

- Poor camera quality, meaning the situation cannot be accurately determined
- Narrow angle of view, and many blind spots even when a large number of cameras are installed
- Information other than images cannot be obtained
- Problems cannot be detected unless the video is constantly watched

Solutions

Panasonic systems solve all of these problems and provide you with solutions to suit your needs

- » Reduce shoplifting damages by monitoring without blind spots
- » Face recognition, matching, and searching to detect repeat shoplifters and wanted criminals
- » High resolution data to perform detailed checks for detecting problems
- » Multi-site (multiple store) monitoring with a network
- » Product lineup for both indoor and outdoor installation
- » One-stop solutions including cameras, recorders, and management software
- » Automatic analysis of customer segments (age, gender)
- » Provide customer flow and heat map information
- » Provide information on customer segment changes by time of day

Entrance

Information such as faces, clothing, and entry times of customers needs to be accurately identified at the store entrance. When damage such as shoplifting is confirmed at a later time, a variety of information related to the criminal can be obtained from the video captured at the entrance. The face information of customers can also be used to immediately detect the entry of repeat shoplifters and wanted criminals to prevent damage in advance by enhancing the store security system.



Providing Smooth Images with a High Image Quality

i-PRO SmartHD series network cameras can capture high resolution images. They can clearly depict people's faces and clothing (colors). Movements can be captured at a maximum rate of 60 frames per second (some models) to ensure quick movements are not missed, and enable playback of smooth video.

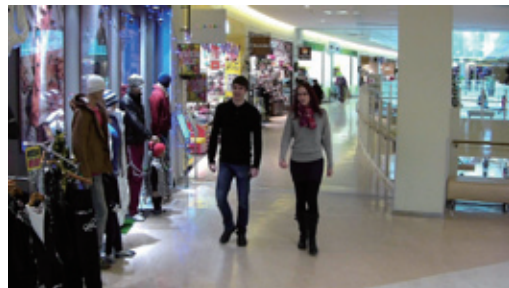

Face Matching *

Specific faces can be registered in advance to send an alarm when they are detected. The faces of repeat shoplifters and wanted criminals, etc. can be registered in the system from data recorded in the past. Information can also be shared between stores by importing generic photo data in the JPEG format, etc. Alarms can notify the operator by displaying pop-ups on the screen, emitting warning sounds, or flashing the camera on the map, etc.

* i-PRO management software and a face recognition system are required in addition to a network camera.

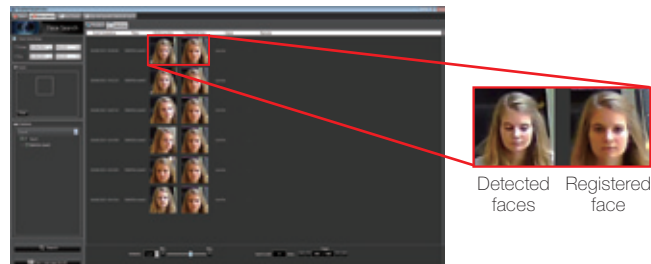

Clearly Capturing Images in Locations with a Large Difference in Illumination



In installation environments with differences in brightness, the Super Dynamic (SD) function brightens dim areas with low visibility and reduces the brightness of areas where blown-out highlights can occur due to over-brightness, providing a natural image that is easy to view. In shop entrances, this enables the capturing of sharp images of people's faces as they enter from the outside when exposed to direct sunlight. With the Super Dynamic (SD) function, the camera can be installed without worrying about lighting conditions that vary based on the time of day and season.

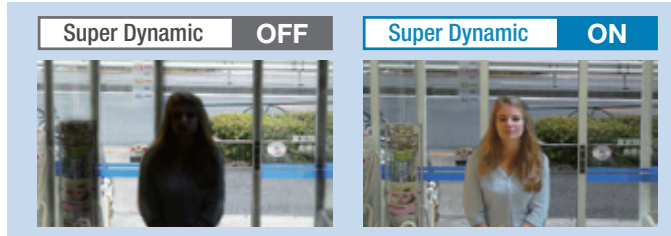

Face Search *

Face images can be used to perform searches. For example, face images of suspicious people detected on the sales floor can be searched to track information on a timeline, including what time they entered the store and which sales floor they passed. Whether suspicious people have shoplifted, etc. after entering the store can also be immediately searched for and checked.

* i-PRO management software and a face recognition system are required in addition to a network camera.

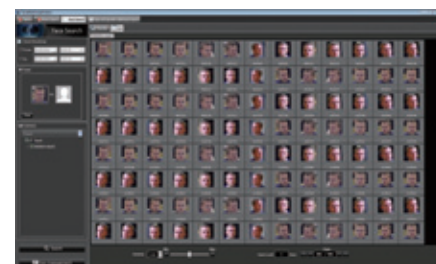

Sales Floor

Sales floors require a wide range of monitoring without blind spots. Shoplifting needs to be able to be viewed from any position of the sales floor and have video evidence recorded. Tampering of products also needs to be immediately discovered to ensure the safety of products and customers. Products missing from shelves can also be checked from camera video to enable products to be accurately restocked to prevent lost sales.



360-degree Monitoring without Blind Spots

The 360-degree Network Camera can capture images around the camera lens in all directions. Available modes include Fisheye, Double Panorama, Panorama, Quad PTZ, and 4 Stream, and the camera can output video images based on the selected video mode for reduced loads on the viewing system.

A high resolution of up to 9 megapixels (2,992 x 2,992) enables people's faces to be captured clearly.



This is the **Panasonic** difference !

De-warping

The 360-degree Network Camera can generate and output video images for each mode within the camera unit. Also, the Network Disk Recorder (WJ-NV300) or i-PRO Management Software (WV-ASM200) can be used on 360-degree omnidirectional images captured by Fisheye Mode to convert to a format that is easier to view, such as Quad PTZ. Because the 360-degree omnidirectional video image is stored in the recorder, nothing is missed within the viewing area.

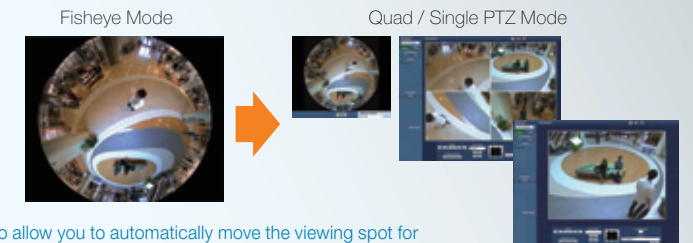

In addition, the area that you want to view can be selected using a controller or mouse to allow you to automatically move the viewing spot for patrolling the area. Even during patrolling, areas not visible on the screen are all stored in the recorder in Fisheye Mode so that nothing is left unseen. The Pan-Tilt of the 360-degree Network Camera does not use mechanical components, and so provides a smooth movement without the mechanized wear that could adversely affect camera longevity.

PTZ Camera for Wide Range Monitoring and a High Zoom Ratio

Normal fixed lens cameras can only monitor in a certain direction, but the lens of a PTZ camera can be operated remotely to switch to the direction you want to view. Detailed areas can also be zoomed in. Since the cameras can be infinitely rotated 360-degree at a high speed of 300 degrees/sec, you will not miss the subjects you want to monitor.

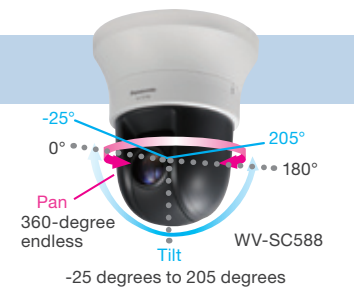

Preset Position / Preset Sequences

If the locations you want to monitor are fixed, you can register them in advance and move to them with a single touch or automatically patrol the registered locations. Data can be saved to a recorder when automatically patrolling the registered locations, without intervention by an operator. Ranges that cannot be covered with a single fixed lens camera can be covered by patrolling.



Auto tracking

The pan, tilt, and zoom functions can be combined for automatically tracking the movement of a subject. If the tracked subject moves out of the camera's shootable range, notification is sent to other cameras so that the tracking process can be carried on without interruption.



Cashier

Problems may occur at cash registers because employees and customers exchange cash and credit cards. By recording clear video and audio evidence of these interactions, the cause of problems can be identified to implement countermeasures. Unauthorized use of cash registers can also be captured with certainty and checked via the recorded video. Installing cameras also deters crime.



Able to Identify Even Types of Banknotes

i-PRO SmartHD series network cameras can capture high resolution images. A camera installed above a cash register enables not only the interaction between employees and customers to be checked, but even the type of banknotes to be identified. If a problem occurs at a register, the image evidence can be checked the accurately understand and resolve the situation.



Monitoring a Wide Area and Playing Back Audio for a Specific Area

With a combination of a 360-degree Network Microphone and a 360-degree Network Camera, the audio of a specific location in the video can be heard by itself.

For example, a single 360-degree Network Microphone with 360-degree Network Camera can be installed above multiple cash registers, enabling the separate conversations at each register to be heard in detail. This enables the cause to be immediately identified when a problem occurs and check whether the employee is dealing with the customer appropriately.

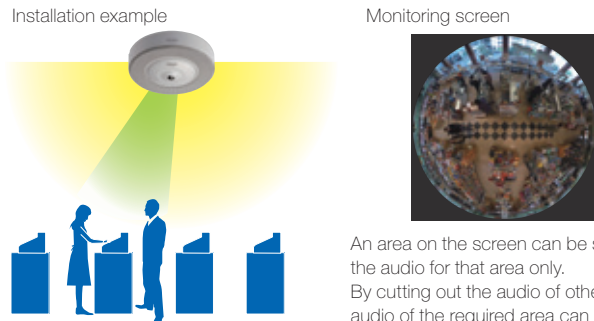

An area on the screen can be specified to hear the audio for that area only. By cutting out the audio of other areas, the audio of the required area can be clearly heard.

360-degree Network Microphone WV-SMR10



» 360-degree audio monitoring

With microphone arrays, 360-degree audio monitoring from a specified direction is possible.

» Specifying a desired direction on a camera image

While watching the 360-degree Network Camera (WV-SFV481 / WV-SFN480 / WV-SW458 / WV-SF448 / WV-SF438) image, audio from the desired location can be freely specified by clicking on that location.

» Synchronizing with the Network Disk Recorder

After recording audio to a Network Disk Recorder*, the sound collecting direction can be specified while playing back the recorded image of the 360-degree Network Camera.

* Models WJ-NV300 and WJ-ND400 are supported

» Can be installed with a 360-degree Network Camera as one unit

The microphone can be neatly installed in one place by integrating it with a Panasonic 360-degree Network Camera.

Backyard

In backyard locations, people other than store personnel, such as distributors, move in and out of the store outside business hours. It is necessary to accurately monitor the movements of people and objects. The camera can automatically adjust its brightness with flexibility whether the lights are on or off, to provide the optimal image for the current conditions.



Strong Low Light Performance in Color

Even in dark locations, color images with low noise can be reproduced to clearly view the movement of people. This is effective for not only backyard locations, but also sales floors, etc. after the store has closed.

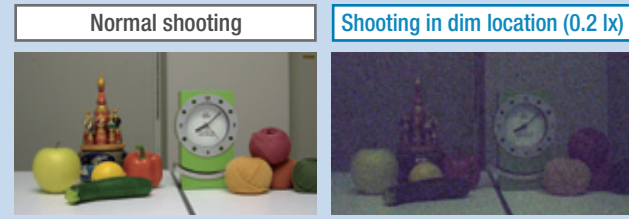

Monitoring Locations Such as Long Corridors

Provide clear images of corridors and narrow and long locations (such as product warehouses or storage rooms) with the focus adjusted for both the close area and the far area.



Day / Night Automatic Mode Switching

In locations where it is bright during the day but dark at night, the camera can automatically determine the brightness of the area and record video under the optimum conditions.

During nighttime hours, the camera automatically switches to black-and-white video for providing footage with high visibility.

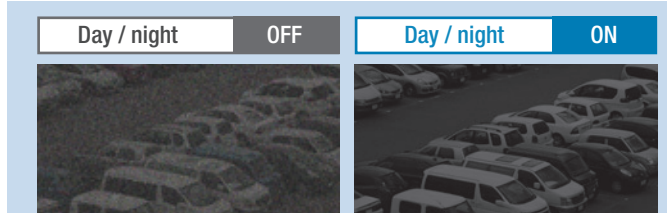

Wide Coverage & Low Distortion

Backyards feature locations with low ceilings and little space between the wall and the objects to capture, which cannot be fully covered with regular cameras. The i-PRO SmartHD lineup features compact models that exceed a maximum angle of view of 100 degrees. They provide natural images with little distortion even when capturing a wide angle.



Migrating from an Analog to an IP Network (Utilizing Existing Analog Equipment)

When migrating from current analog cameras to highly functional high resolution network cameras, the existing analog cameras and coaxial cables can be utilized.

■ Utilizing analog cameras

An encoder (WJ-GXE500/WJ-GXE100) can be used to connect existing analog cameras to an IP network, enabling video to be recorded and managed with the same recorder as network cameras.

Basic System Connection Example

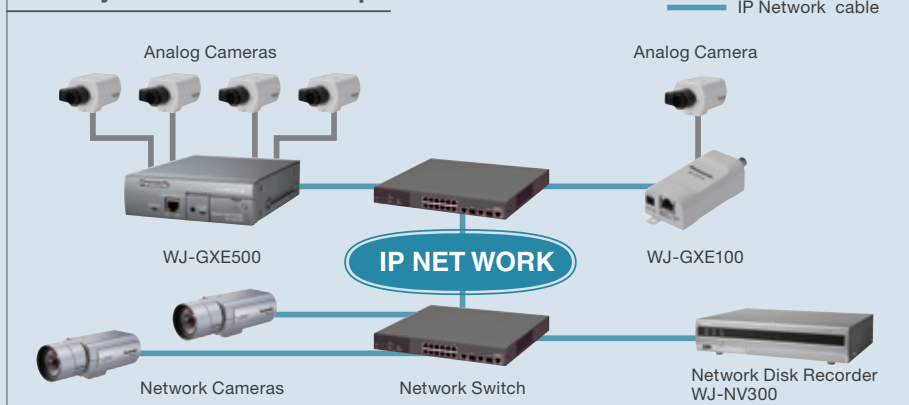

Intelligent Video Motion Detection (i-VMD)

Cameras notify users of changes without constant human monitoring



Some stores may have difficulty having security personnel constantly monitoring the camera image. Cameras can notify personnel when the following changes occur in the area monitored by the camera. This can be linked to send e-mail, play a warning sound, display a warning on the screen, turn on a rotating light, or change the music in the store, etc.

■ Intruder Detection

Set an area in the image where intrusion is prohibited to detect moving objects such as people in that area



■ Scene Change Detection

Detect changes in the scenery, such as when the direction of the camera is changed, the lens is covered with a cloth, or painted with spray paint

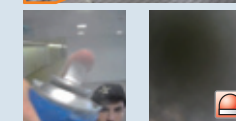

■ Loitering Detection

Detect when suspicious people are loitering around the store outside of set times



■ Direction Detection

Detect when people try to exit from a one-way entrance and when cars try to enter from a one-way exit



■ Object Detection

Detect when paintings hung on a wall go missing or when suspicious objects are placed in an empty location



■ Cross Line Detection

Specify a line on an image to detect objects that cross that line (in one direction or in both directions)

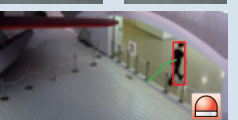

Parking Lots

Many stores have an adjacent parking lot and it is necessary to obtain information relating to trouble that occurs in it. Situations such as car crashes, pedestrian accidents, and non-customer cars parking for extended periods of time can be checked at any time via the captured video. Suspicious persons can be detected before they enter the store when they are in the parking lot or in the vicinity, to send notifications and the parking lot video can be checked to obtain information on the car of a shoplifter (vehicle type, model, color, number plate) and the direction it traveled.



High Resolution/Wide Range 4K Camera



A single 4K camera can capture video of a wide area such as a parking lot. A part of the image can be zoomed in as necessary to check an area in detail. A 4K camera has 27 times the resolution of an analog (VGA) camera, 9 times that of an HD (1,280 x 720) camera, and 4 times that of a Full HD (1,920 x 1,080) camera.

Cropping function

Specific areas can be selected from the entire image to cut out. This enables monitoring to be focused on a specific area such as the entrance or corridor of a parking lot, while viewing the entire image.



4K (3,840 x 2,160)



Cropped image 1



Cropped image 2



Cropped image 3



Cropped image 4

HD (1,280 x 720) x 4

Select the Specialized Model for Your Installation Environment

Rainwater protection for outdoor installations

The outdoor models have a weatherproof and dustproof structure that is rated IP66 for outdoor installation without requiring insertion in a special housing or other weatherproofing protection.

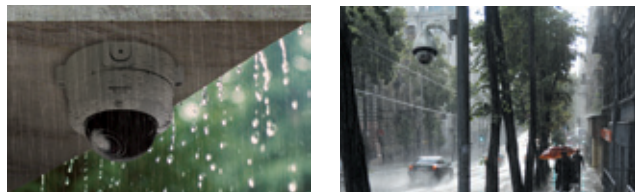

Temperature protection for outdoor installations

Models can be selected to match your specific installation conditions and can be installed in environments with temperatures ranging from +55°C to -50°C. * The supported temperature range varies depending on the specific model.



This is the **Panasonic** difference !

Dehumidification Device

The network camera outdoor models have a built-in dehumidifier device to lower the internal humidity for preventing cloudiness due to condensation. This eliminates blurry video images caused by clouding of the camera dome cover when installed in locations with high humidity or extreme temperature changes over the course of the day.



Rain Wash Coating



Water droplets from rain can adhere to the dome cover of the camera and hinder the shooting of clear images. In our Rain-wash coated models, a special coating is applied so that water droplets are repelled allowing clear images to be recorded even during rainfall. This coating is also effective at repelling dirt so that cleaning of the dome cover is required less frequently.

* WV-SPV781L / WV-SW598 / WV-SW397A

Coated areas are resistant to water droplets



Non-coated

Coated areas are resistant to dirt



Non-coated

Rain-wash coated

Rain-wash coated

Vandal Resistant



When installed in locations that are prone to vandalism and tampering, measures are required for preventing damage to the camera. Models featuring the Vandal Resistant mechanism are ideal for installation in these types of locations.



This is the **Panasonic** difference !

Vandal resistant mechanism

Models featuring the Vandal Resistant mechanism include a shock absorber around the internal lens. Even if the dome cover is subjected to a potentially damaging impact, the shock absorber will absorb this impact to protect the internal structure from damage.



0 lux Pitch Dark Locations



Cameras with an IR LED can be used to monitor environments that are completely dark. This enables areas without the level of illumination required to be monitored to prevent graffiti, illegal dumping, and property destruction. The IR LED can illuminate a wide area so that monitoring is not limited to a specific part of the image. The built-in IR LED can capture subjects up to 30 meters away. The lens design also has a wide angle of view to allow monitoring over a wide area.

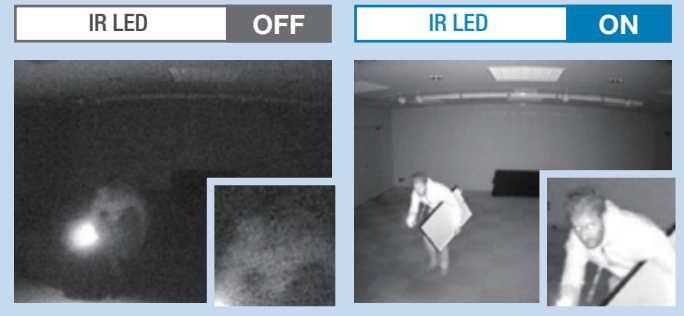

Utilizing Network Cameras for Marketing

New uses other than crime prevention and monitoring

The information from network cameras that capture 24-hour video for crime prevention is starting to be used for marketing. Panasonic network cameras have intelligent functions that enable a variety of information beyond that of simple video.

People counting, age and gender statistics

Cameras installed at the store entrance, etc. can be used to detect the number of customers and their age and gender, and output statistic data. Information on customer trends at a certain time of the day, such as women in their 40s often visiting at a certain time of the days, can be used to implement measures for efficiently increasing sales, such as changing the products on the sales floor or performing time sales. (Network Disk Recorder WJ-NV300 + Additional Business Intelligence Kit WJ-NVF30 or Face Recognition System WV-ASF900 + i-PRO management software WV-ASM200 + Extension software WV-ASE231 are required.)

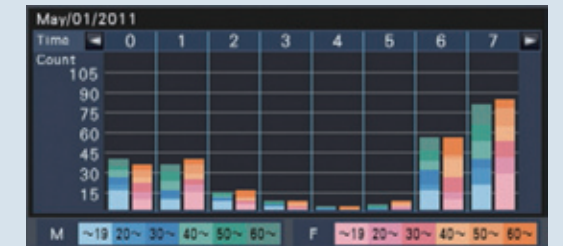

Using the WV-SFV480/WV-SFV481 9 mega pixel 360-degree network camera

Heat map function

Images of a store captured with the fisheye lens of a 360-degree camera (WV-SFN480/WV-SFV481) can be used to highlight places that people pass or gather in. This enables stores to adopt a layout that maximizes sales by optimizing the product placement and the positions of aisles and sales floors.

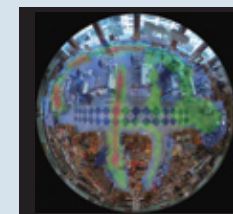

Counting passers-by in a specific location

A virtual line can be drawn on images to count the number of people that pass that line. Numbers can be counted in two directions; from the left to the right of the image and from the top to the bottom of the image. The numbers of customers visiting a specific sales floor in the store can be used as information for measuring the result of sales initiatives and implementing new initiatives.

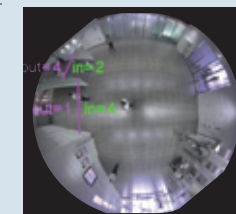

Moving Objects Remover (MOR)

Moving objects in an image can be removed. This enables customers passing in front of product shelves to be removed to check images of product sales and the timing for restocking products. Removing customers from images also enables video to be captured in situations where privacy is required.



Example Store Installation

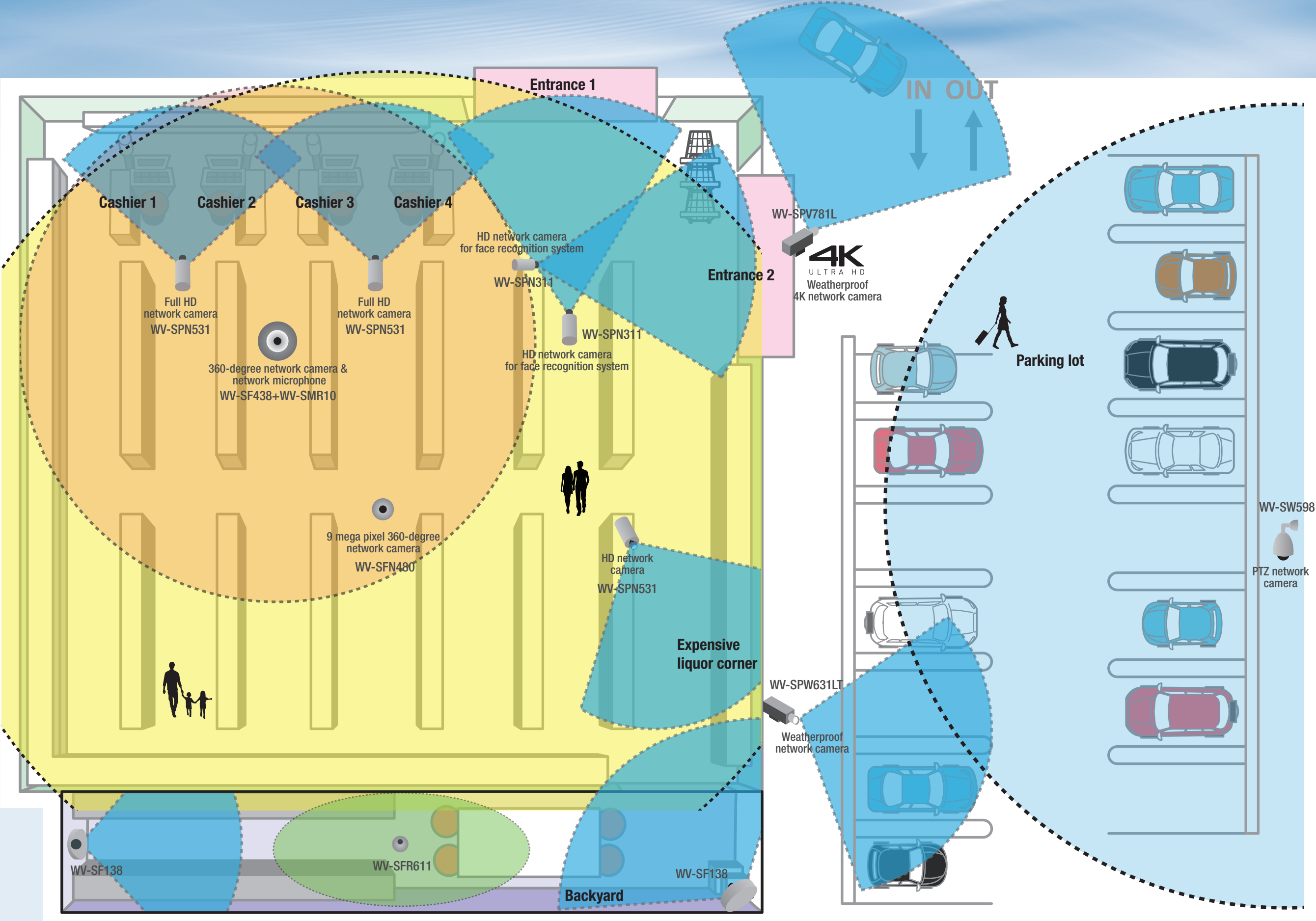

Lineup

Network Cameras

For entrances/exits

Capture customers' faces and clothing in detail with HD resolution

Super Dynamic HD Network Camera

WV-SPN311



Lens : optional



For sales floor ceilings

Capture 360-degree video at 4K level resolution

360-degree Indoor Dome 9 Megapixel Network Camera

WV-SFN480

Automatic tracking of moving objects with Full HD video, high speed pan/tilt, and high magnification

Super Dynamic Full HD PTZ Dome Network Camera

WV-SC588

High resolution Full HD dome camera with IR LED

Super Dynamic Full HD Dome Network Camera

WV-SFN631L



For areas around cash registers

Full HD resolution to clearly identify the type of banknotes

Super Dynamic Full HD Network Camera

WV-SPN531



Lens : optional



For parking lots

Full HD resolution camera for outdoor installation with IR LED for capturing 0 lux situations

Super Dynamic Full HD Weatherproof Long Focus Type Network Camera

WV-SPW631LT

Full HD PTZ camera for outdoor installation with 90x zoom for detailed capturing of remote locations

Super Dynamic Weather Resistant Full HD PTZ Dome Network Camera

WV-SW598

4K Vandal Resistant Weatherproof Network Camera

WV-SPV781L



For backyards

Compact size Full HD wide range dome camera

Super Dynamic Full HD Dome Network Camera

WV-SF138

Clear capturing in dark locations. IR LED equipped as standard. Supports the capturing of object collisions, etc.

Super Dynamic Full HD Dome Network Camera

WV-SFR611



Network Disk Recorder

Recorder that can be expanded to 4TB from simple configurations

Network Disk Recorder

WJ-NV300

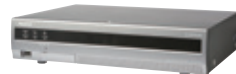

Enables head counting and gender and age detection with a recorder

Additional Business Intelligence Kit for WJ-NV300 / WJ-NV200

WJ-NVF30

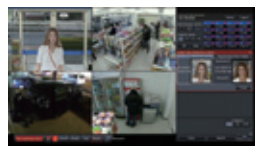

ONVIF All the above models support Onvif .

Software Panasonic can provide a one-stop solution that includes management software in addition to cameras and recorders.

Face Recognition System WV-ASF900



Face Recognition System running in the video surveillance system

- Add-on face matching function: Add the face matching function by simply adding the necessary devices and the software
- Can be connected up to 20 cameras on a server.

Face search

- Face images that camera detected are stored, and it can be searched later.
- By searching the face DB, you can display the result of each cameras in chronological order and find movement locus of persons.
- Specify camera or date in detected face images and display the result in the list in similarity order.



Face Matching

- When it is matched with registered people, alarm of face matching is output in real-time, and display an alarm history in the list.
- Specified screen image can be played back on control monitor with double-clicking on an alarm history.

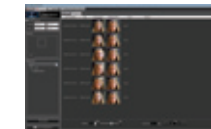

People counting, Age and Gender Statistics

- When it is matched with registered people, alarm of face matching is output in real-time, and display an alarm history in the list.
- Specified screen image can be played back on control monitor with double-clicking on an alarm history.



Basic System Connection Example

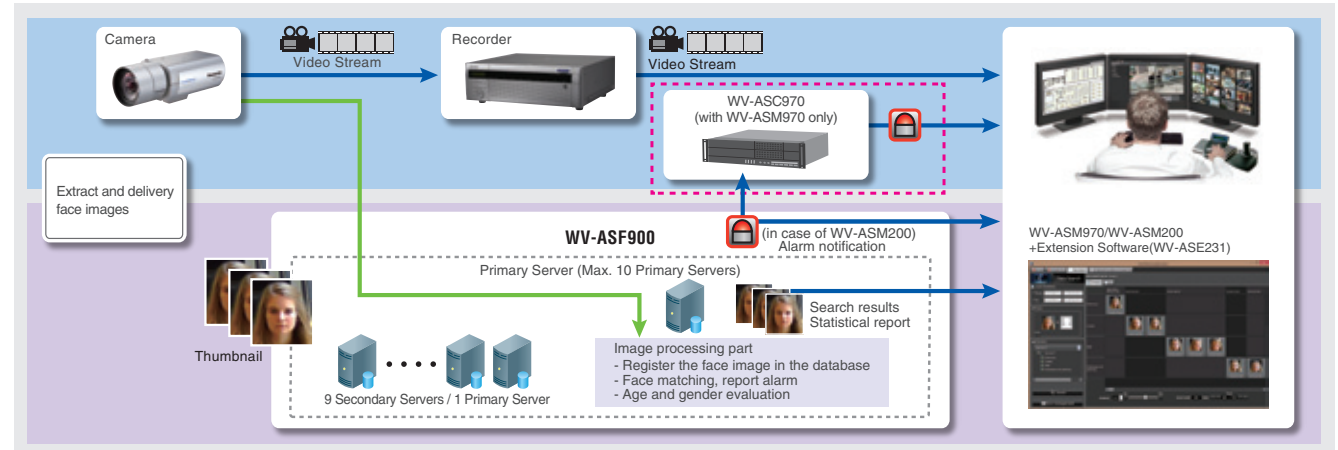

i-PRO Management Software

WV-ASM200

Extension Software

- WV-ASE201 / ASE202 / ASE203 / ASE204 / ASE205 / ASE231 (for WV-ASF900)



(System Controller WV-CU950 and monitor displays are optional.)

Optional Accessory

Ethernet System Controller with 3D-Joystick & Jog/Shuttle

WV-CU950
(WV-ASE201 is necessary.)



- Supports 16:9 video stream and 16:9 HD monitor. Displays 16:9 and 4:3 videos from IP cameras on the same screen.
- H.264 recording data in the SD/SDHC/SDXC memory card can be downloaded.
- Convert file format from n3r (proprietary format) to MP4.
- Up to 100 recorders, 64 encoders and 256 directly connected cameras can be registered. Up to 6,400 cameras registered in the recorders and 256 cameras registered in the encoders are automatically registered in the WV-ASM200 (the number of the cameras depends on the recorder and encoder).

WV-ASE201

- Add Live window, Map window in addition to the Operation window (3 monitors)
- Control using the Ethernet System Controller WV-CU950
- Expand the maximum numbers of screens to 20.
- * To use the multi-monitor function, it is necessary to install an additional video card on the PC in use.

WV-ASE202

- Expand the maximum numbers of screens to 64.
- Up to 4 live windows.
- Multi-monitor function using up to 6 PC monitors.
- To display the operation window, the map window and the 4 map windows simultaneously.

WV-ASE203

- Expand the maximum numbers of registered recorders, encoders and cameras to 100, 64 and 256 respectively.
- Up to 4 licenses for the WV-ASE203 can be added.

WV-ASE204

- Decoder registration: Up to 10 decoders

WV-ASE205

- Visibility Enhancement Function

- Spatial Tonal Correction
- Snowfall and Rainfall Noise Reduction
- Multi-frame Synthesis Noise Reduction



Spatial Tonal Correction, Snowfall and Rainfall Noise Reduction

System Example

Example of Simple Configuration

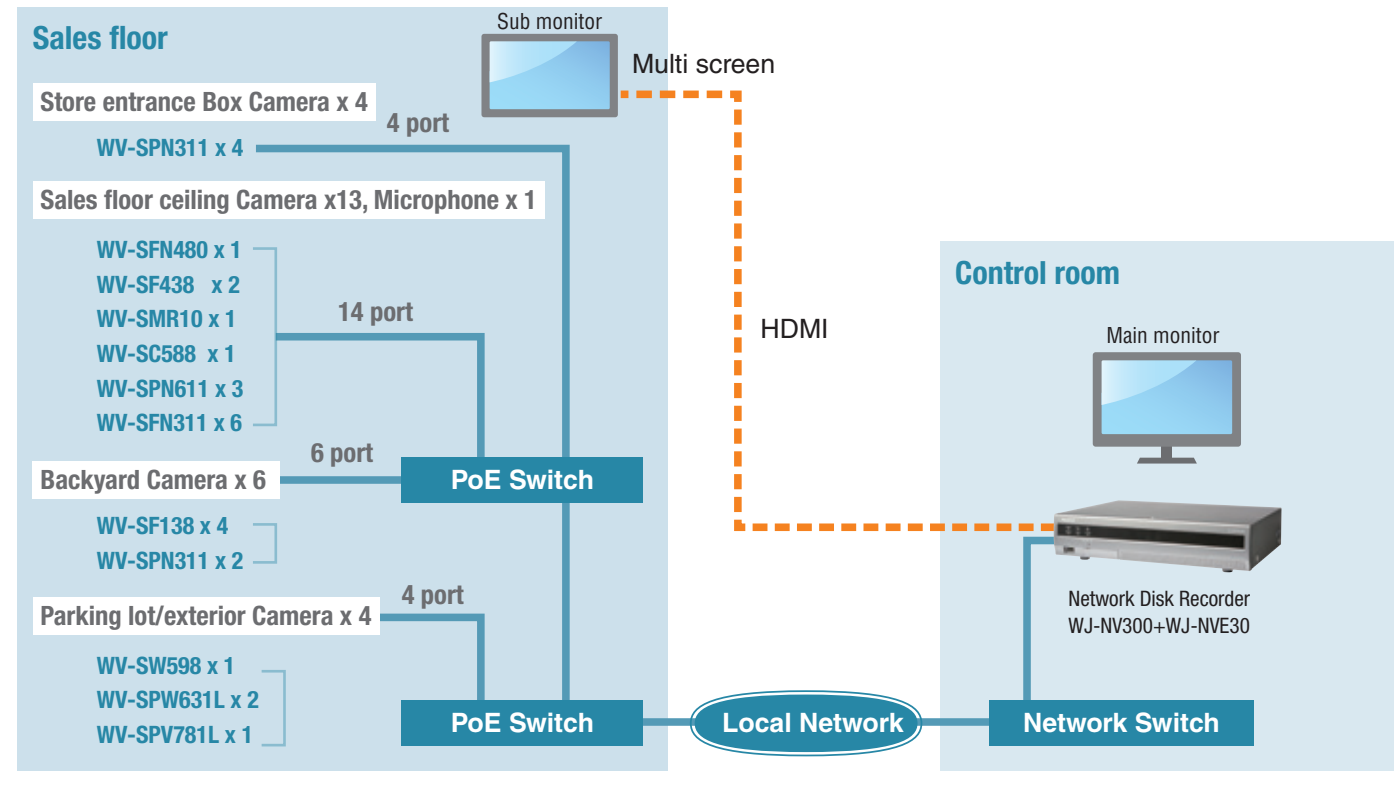

Centralized Management of Multiple Locations + Face Recognition System

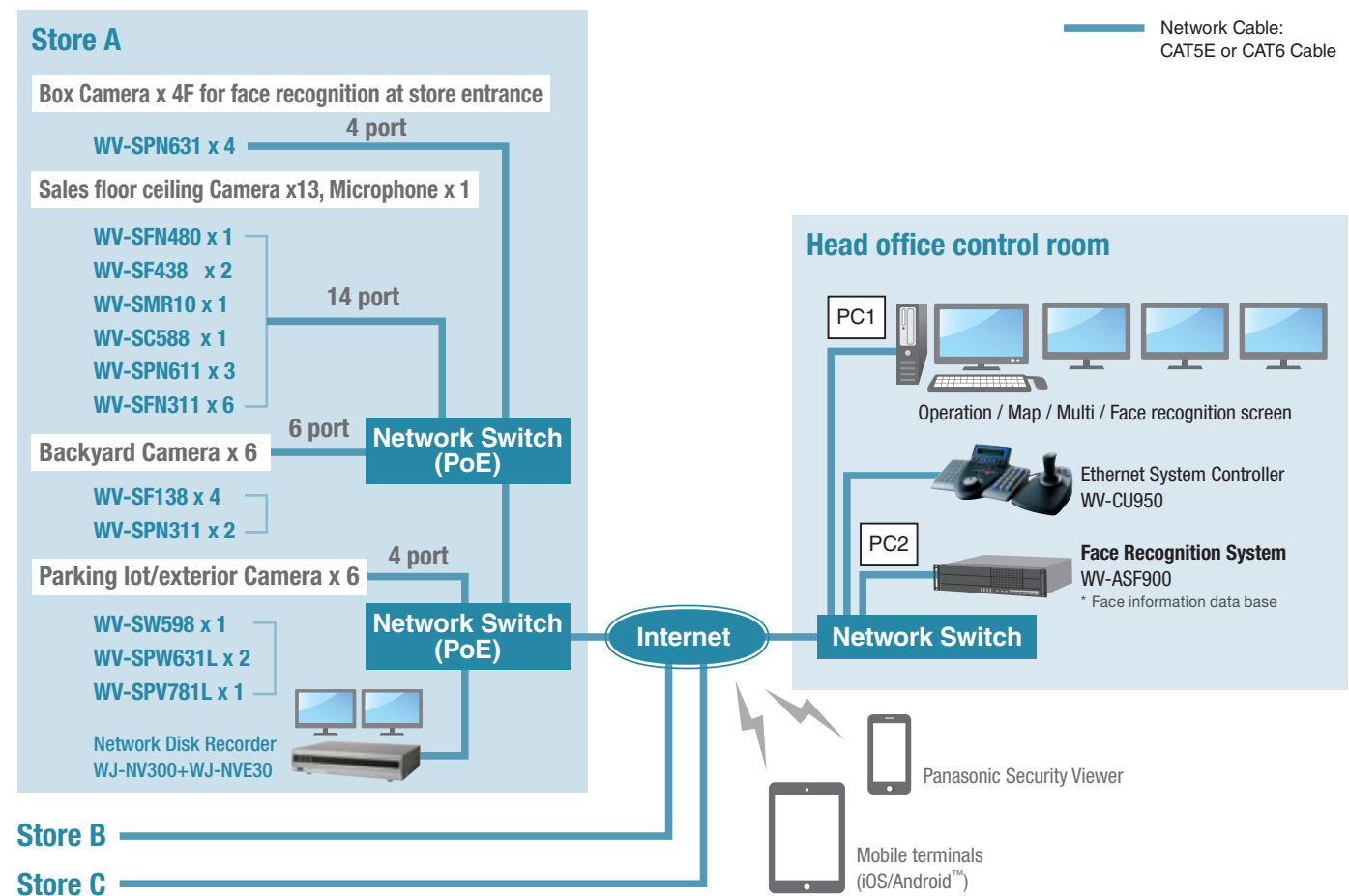

Case Study

Tricot (Clothing Retail Store), Chile



Project Outline and Solution Needed for Customer

- Install IP cameras in store, and monitor at the store and control room at the Tricot HQ.
- The purpose of the system is for security and marketing, such as product arrangement and price, and whether the store follows instructions or not.
- Counts the number of visitors, detects the age and gender of visitors using a face recognition system (WV-ASF900), and makes use of the results for marketing strategy. The first stage project is for 20 locations in Santiago.

System-Diagram

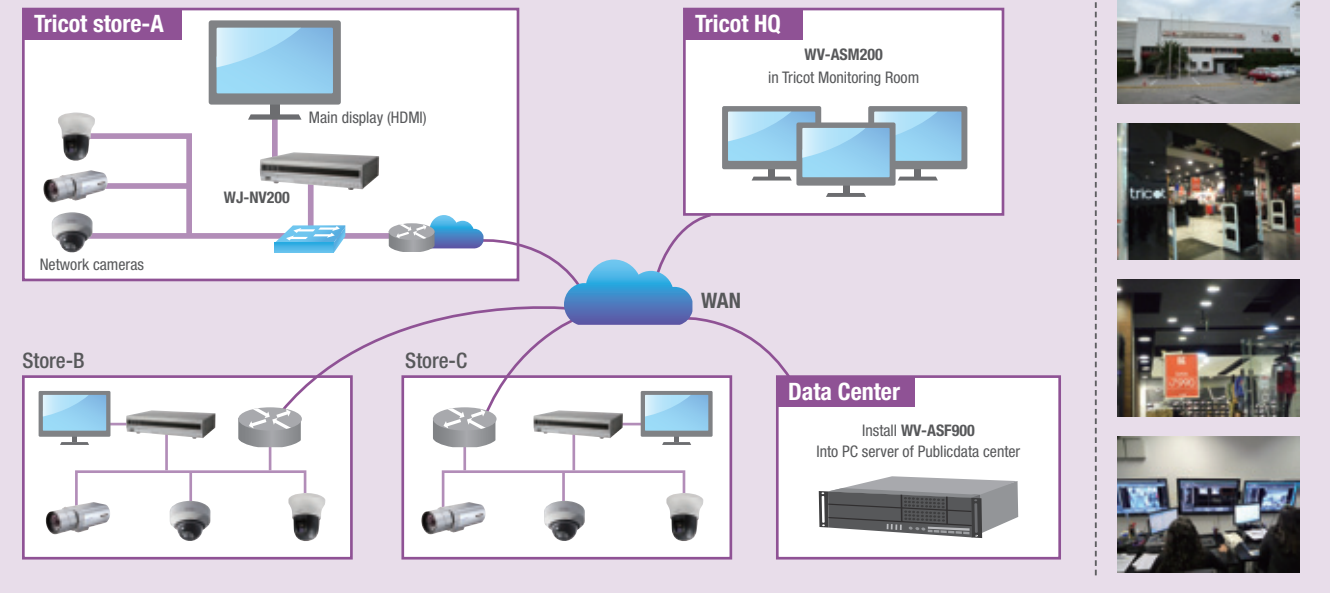

S-PAL Station Building Shopping Center (Sendai Terminal Building Co., Ltd.), Japan



The "S-PAL" shopping center is located in Sendai Station, which has more than 83,000 passengers each day. Inside is the "S-PAL" shopping center, which has a total of 171 Panasonic network cameras operating to enable a comfortable store environment for customers and employees.

<Background>

As a large facility used daily by a large number of customers, S-PAL was considering adopting cameras for checking the status of each floor and corner. Some sales floors already had analog cameras, but time and money was being spent on installing coaxial cables and power cables when adding or moving cameras, so S-PAL was considering adopting network cameras that can be connected via a LAN cable and also powered via a LAN cable (PoE).

<System Adopted>

Cameras were installed in store aisles, escalator doors, entrances/exits, and side doors, etc. Cameras without blind spots were installed in sales floors, with these cameras not causing discomfort in regular customers, but also being visible enough to deter crime. Monitors were installed to enable video to be viewed from staff rooms, and enable employees to immediately identify when a problem arises in a sales floor or when assistance is needed.

<Store Network>

In addition to the Sendai store, the same system was constructed at the Koriyama, Yamagata, and Fukushima stores. An environment for viewing the video from each store was set up at the head office in Sendai, and system problems could be handled at the head office.



Clothing sales floor

Control room

Large monitor installed in the office

Ms. Ito Mr. Shigihara